

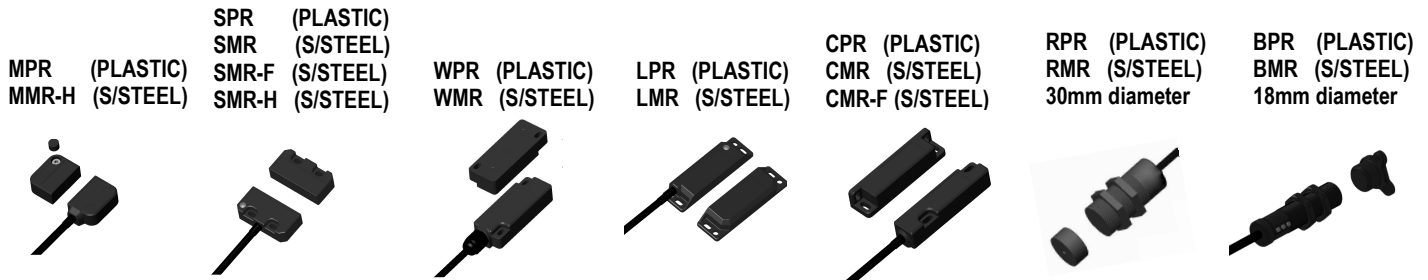

Non Contact Magnetic Safety Switches

Operating Instructions



IMPORTANT NOTE:

Read and understand these instructions before installing, operating, or maintaining this equipment.

The product is designed to be a component of a customized safety oriented control system. It is the responsibility of the user to ensure the correct overall functionality of its systems and machines. IDEM, its subsidiaries and affiliates, are not in a position to guarantee all of the characteristics of a given system or product not designed by IDEM.

APPLICATION:

Coded Non Contact switches are designed to interlock hinged, sliding or removable guard doors. They are specifically advantageous when:

- a) poor guard alignment exists
- b) high hygiene requirements exist e.g. food industry hose down
- c) a long mechanical life is required (no touching parts).

When used in combination with a Dual Channel Safety Relay or Control Device, Magnetic Non-Contact Switches can be used to provide protection up to Category 4 and PLe to ISO13849-1.

OPERATION:

All Magnetic Non-Contact Safety Switches are designed to conform to EN60947-5-3 and be used as directed by ISO14119 and EN ISO12100. They have magnetic sensing which provides a wide sensing distance and provides a high tolerance to misalignment after sensing. They can operate in extreme environments of temperature and moisture.

IMPORTANT:

The Risk Assessment for the particular application should include the risk of spare actuators. Spare actuators should not be readily available and must be securely controlled.

The safety functions and mechanics must be tested regularly. For applications where infrequent guard access is foreseeable, the system must have a manual function test to detect a possible accumulation of faults. At least once per month for PLe Cat3/4 or once per year for PLd Cat3 (ISO13849-1). Where possible it is recommended that the control system of the machine demands and monitors these tests, and stops or prevents the machine from starting if the test is not done. (See ISO14119).

INSTALLATION:

Installation of all Non Contact Switches must be in accordance with a risk assessment for the individual application.

Installation of the devices must be carried out by a competent person with appropriate experience of machine control safety integration.

The use of a Safety Relay or Control Device is recommended for monitoring magnetic switches. These devices monitor 2 redundant circuits as per ISO13849-1 for up to PLe /Category 4 protection. M4 mounting bolts must be used to fix the switches, except RPR / RMR / BPR / BMR types, these require fitting through clearance holes using the lock nuts supplied.

Tightening torque for mounting bolts to ensure reliable fixing is 1.0 Nm. Always mount on to Non Ferrous materials. The recommended setting gap is 5mm. The Safety switch must not be used as a mechanical stop or be adjusted by striking with a hammer. The actuator must not be allowed to strike the switch. Do not mount adjacent switches or actuators closer than 30mm.

Typical misalignment tolerance after setting is 5mm.

IMPORTANT: The NC switch contacts are potential free and are internally fused. To protect the internal fuse, all switches must be externally fused at a lower rating (see Technical data).

After installation always check each switch function by opening and closing each guard individually in turn and ensuring that the LED's on the Safety Relay or Control Device are illuminated when the switch is closed and are extinguished when the switch is open. Check that the machine stops and cannot be re-started when each switch is open.

For MPR types, fit the protective screw covers after the final checks have been completed.

ACTUATOR OPERATING DIRECTIONS FOR OPTIMUM PERFORMANCE:



Quick Connect (QC) M12 8 way Male Plug (on Flying Lead 250mm) (Pin view from switch)	Flying Lead Colours	Circuit (Actuator present)
4	Yellow	Auxiliary (NO)
6	Green	Auxiliary (NO)
7	Black	NC 2
1	White	NC 2
2	Red	NC 1
3	Blue	NC 1

For all switches the NC circuits are closed when the guard is closed and the actuator is present.

MAINTENANCE:

Monthly: Check alignment of actuator and look for signs of mechanical damage to the switch casing. Check wiring for signs of damage.

Check each switch function by opening and closing each guard individually in turn and ensuring that the appropriate LED's on the Safety Relay or Control Device are illuminated when the switch is closed and are extinguished when the switch is open. Check that the machine stops and cannot be re-started when each switch is open.

Never repair any switch, actuator or integral cables. Replace any switch displaying signs of mechanical damage to the casing or cables.

These requirements form part of the product warranty.



WARNING: DO NOT DEFEAT, TAMPER, OR BYPASS THE SAFETY FUNCTION. FAILURE TO DO SO CAN RESULT IN DEATH OR SERIOUS INJURY.

AVERTISSEMENT: NE PAS DESACTIVER, MODIFIER, RETIRER, OU CONTOURNER CETI INTERVERROUILLAGE IL PEUT EN RESULTER DES BLESSURES GRAVES DU PERSONNEL UTILISATEUR.

Original Instructions.

To request this data sheet in other languages please contact info@idemsafety.com
 Um dieses Datenblatt in Deutscher Sprache wenden Sie sich bitte anfordern info@idemsafety.com
 Pour obtenir cette fiche en Français, veuillez contacter info@idemsafety.com
 Para solicitar esta hoja de datos en Español, por favor contacto con info@idemsafety.com

Non Contact Magnetic Safety Switches

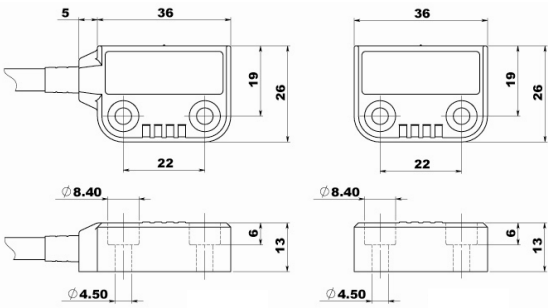

MPR MMR-H

MMR-H version has two 5mm through holes. Hexagon head bolts can be used for ease of cleaning.

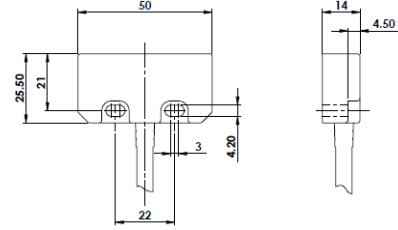

SPR SMR

SMC-F rear fixing version has two M4 x 10mm tapped holes at the rear of housings.

SMC-H version has two 5mm through holes. Hexagon head bolts can be used for ease of cleaning.

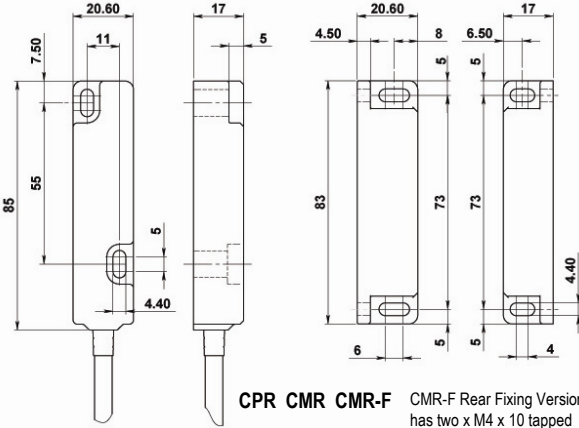

CPR CMR CMR-F CMR-F Rear Fixing Version has two x M4 x 10 tapped holes at rear.

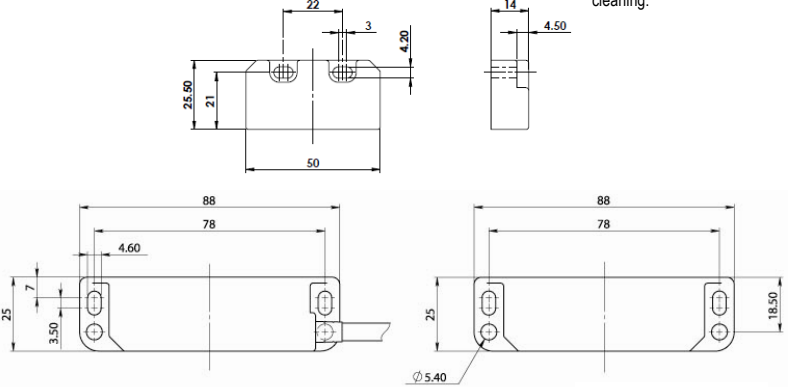

LPR LMR

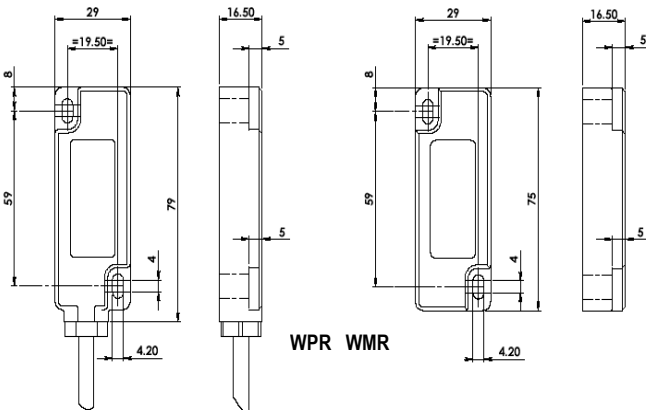

WPR WMR

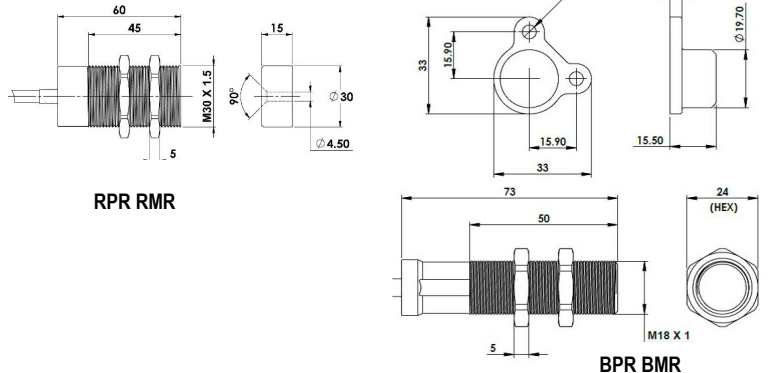

RPR RMR

BPR BMR

Single switch to SCR-2 or SCR-3 Safety Relay

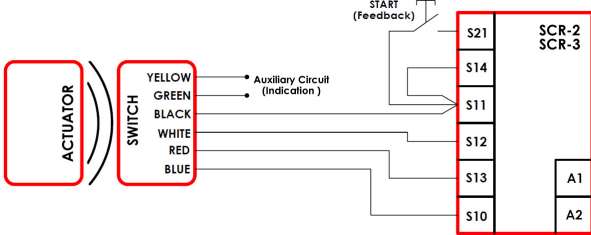

Single switch to SCR-21-I or SCR-31-I Safety Relay (Viper range)

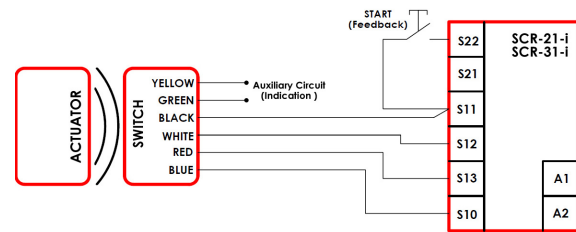

Connecting in series to SCR range

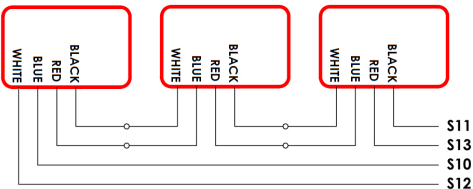

Alternative QC pin out versions:

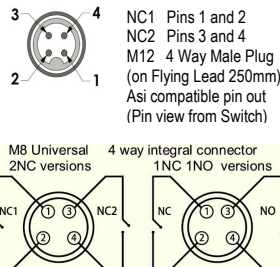

Safety Classification and Reliability Data:

ISO 13849-1 Up to PLe Category 4 (if both channels are used with a PLe control device)
3,300,000 cycles at 100mA load
B10d 8 cycles/hour 24 hours/365 days per year
Usage MTTFd is 470 years

Technical Data:

Standards: ISO14119 EN60947-5-3 EN60204-1 ISO13849-1 UL508

MPR MMR-H RPR RMR BPR BMR Safety Circuits NC
SPR SMR LPR LMR CPR/CMR (2NC) Safety Circuits NC
WPR WMR CPR/CMR (1NC) Safety Circuits NC
Auxiliary Circuits NO
Contact release time <2ms
Initial contact resistance <500 milliohm
Minimum switched current 10V. dc 1mA
Dielectric withstand 250V.ac
Insulation Resistance 100 Mohms
Recommended setting gap 5mm
NC Switching Distance: Sao 8mm (BPR / BMR 7mm)
(Target to target) Sar 20mm
NO Switching Distance Opens before NC circuits close
Tolerance to misalignment 5mm in any direction from 5mm setting gap
Switching frequency 1.0 Hz maximum
Approach speed 200mm/m. to 1000mm/s.
Body Material MPR SPR CPR LPR WPR RPR BPR Polyester
SMR SMR-F SMR-H WMR CMR CMR-F RMR
MMR-H BMR S/Steel 316
Temperature Range -25/80C. 105C. S/Steel for CIP/SIP cleaning
Enclosure Protection IP67 and IP69K (QC versions IP67 for connector)
Cable PVC 6.0mm OD Conductors 0.25 sq.mm
Mounting Bolts 2 x M4 Tightening torque 1.0 Nm

Information with regard to UL 508:

Type 1 Enclosures.
Maximum temperature: 80°C Plastic versions, 70°C S/Steel versions.
Maximum output 24V dc 200mA. Powered by Class 2 or equivalent.