

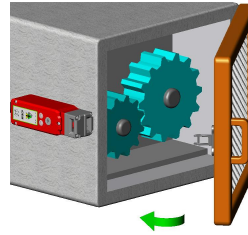

Kobra - Tongue Switches with Guard Locking - Type KL3-SS-P2L

Power to Lock Operating Instructions



Hinged Guard

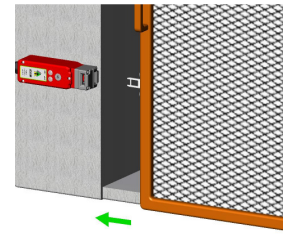

Sliding Guard

Application:

Tongue operated Solenoid Interlock switches are designed to fit to the leading edge of sliding, hinged or lift off machine guards to provide positively operated switching contacts and provide a tamper resistant key mechanism.

They are designed to provide robust position interlock detection for moving guards and will remain locked until the solenoid voltage is removed from the switch.

They are not suitable for machines with a running down time.

It is the responsibility of the user to ensure the correct overall functionality of its systems and machines. IDEM, its subsidiaries and affiliates, are not in a position to guarantee all of the characteristics of a given system or product not designed by IDEM.

Operation:

The switch is rigidly mounted to the frame of the guard or machine. The actuator is fitted to the moving part (frame) of the guard and is aligned to the switch entry aperture. The actuator profile is designed to match a cam mechanism within the switch head and provides a positively operated not easily defeatable interlock switch. When the actuator is inserted into the switch the safety contacts will close only when power is applied to the solenoid. This will then allow the machine start circuit to be enabled. When the solenoid power is removed the safety contacts are opened and the machine circuit is broken.

Installation:

- Installation of all IDEM interlock switches must be in accordance with a risk assessment for the individual application. Installation must only be carried out by competent personnel and in accordance with these instructions.
- M5 mounting bolts must be used to fix the switch and actuator, the tightening torque to ensure reliable fixing is 4.0 Nm. Tightening torque for the lid screws, conduit entry plugs and cable glands must be 1.5 Nm to ensure IP seal. Only use the correct size gland for the conduit entry and cable outside diameter. Tightening torque for the connection terminal screws is 0.7 Nm, max conductor size is 1.0 sq.mm. The switch head position can be selected by loosening the 4 head bolts and then rotating to the position required. Tightening torque for the head bolts is 1.5Nm.
- Always fit a mechanical stop to the guard to prevent damage to the front of the switch. Set the actuator gap to 3mm when the guard is closed and against the stop. (See Fig.A). Use alignment guides to ensure that the actuator enters the switch without interfering with the sides of the switch aperture. Always fit the aperture plug to the unused entry aperture to prevent debris entering the switch mechanism.
- Always use the circuits 11-12 and 21-22 to ensure monitoring of the lock.**
- After installation check operation of all control circuits and the locking function. LED 1 will illuminate when power is applied to A1 and A2 (solenoid feed).

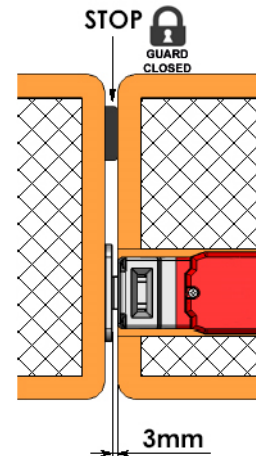
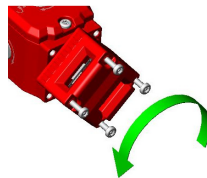

Fig. A

8 actuator entry positions
rotatable head



Internal Terminal Connections:

A1 0V dc
A2 24V dc

- 11-12 Safety Circuit 1 – (must always be used)
- 21-22 Safety Circuit 2
- 33-34 Signal Circuit Guard - (Closed when Guard is closed)
- 43-44 Signal Circuit Guard - (Closed when Guard is open)

LED Function:

Green Solenoid Energised

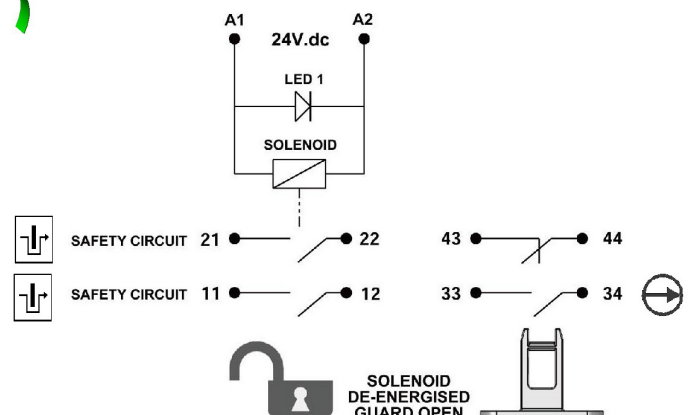

Kobra - Tongue Switches with Guard Locking - Type KL3-SS-P2L

IMPORTANT

The Risk Assessment for the particular application should include the risk of spare actuators. Spare actuators should not be readily available and must be securely controlled. Application consideration must be given to the fixing of the actuator which has to be in a way that prevents disassembly by easy means.

Ensure that the switch holding force (Fzh) is sufficient to withstand the static forces applied during normal use and dynamic effects caused by bouncing of the guard shall not create an impact reaction force which exceeds the holding force. If the expected impact reaction forces are higher than the specified holding force for the switch, then design measures must be applied to avoid the force.

The safety functions and mechanics must be tested regularly. For applications where infrequent guard access is foreseeable, the system must have a manual function test to detect a possible accumulation of faults. At least once per month for PLe Cat3/4 or once per year for PLd Cat3 (ISO13849-1). Where possible it is recommended that the control system of the machine demands and monitors these tests, and stops or prevents the machine from starting if the test is not done. (See ISO14119).

Maintenance:

- Every Week: Check the switch actuator and body for signs of mechanical damage and wear. Replace any switch showing damage.
- Every 6 Months: Check for mechanical damage to switch body or actuator. Isolate power and remove cover. Check screw terminal tightness and check for signs of moisture ingress. Never attempt to repair any switch. Replace any switch displaying damage.
- These requirements form part of the product warranty.**

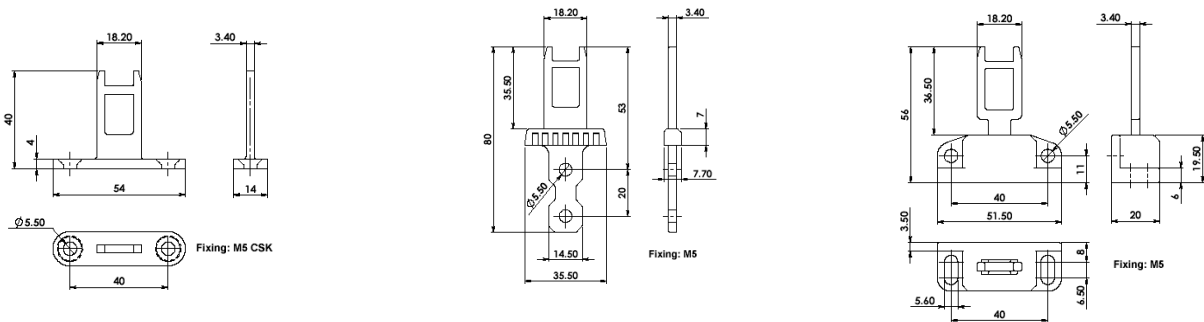

Actuator insertion:

11/12	Open	Solenoid energised
21/22	Open	Solenoid energised
33/34	Closed	Locked
43/44	Closed	Open Tongue Inserted

Conforming to Standard:	ISO14119, IEC60947-5-1, UL60947-5-1, ISO13849-1
Safety Classification and Reliability Data:	
Mechanical Reliability B10d	2.5 x 10 ⁶ operations at 100mA load
ISO 13849-1	up to PLe / Cat.4 depending upon system architecture
EN 62061	up to SIL3 depending upon system architecture
Safety Data - Annual Usage	8 cycles per hour / 24 hours per day / 365 days
PFHd	3.44 x 10 ⁻⁸
Proof Test Interval (Life)	35 years
MTTFd	356 years
Solenoid Voltage (by part number)	24V ac/dc (12W.)
Safety Contacts 11/12 21/22 33/34	Utilization Category AC15 A300 3A.
	Thermal Current (Ith) 5A
Overload protection fuse (fuse externally)	10A. (FF).
Auxiliary Contact 43/44	230V.ac/dc 0.5A. Maximum.
Rated Insulation Voltage	600VAC
Rated Impulse Withstand Volt	2500VAC
Travel for Positive Opening	10mm
Approach Speed	200mm/m. to 1000mm/s.
Man. Actuation Frequency	2 cycle/sec
Actuator entry minimum radius	175mm Standard 100mm Flexible
Case Material	Stainless Steel 316
Head Material	Stainless Steel 316
Actuator Material	Stainless steel 316
Enclosure Protection	IP67
Operating Temperature	-25°C to 40°C
Holding Force	F1Max: 3000N. Fzh: 2307N.
Vibration	IEC 68-2-6, 10-55Hz+1Hz, Excursion: 0.35mm, 1 octave/min
Conduit Entry	Various (See Sales Part Numbers)
Fixing	4 x M5

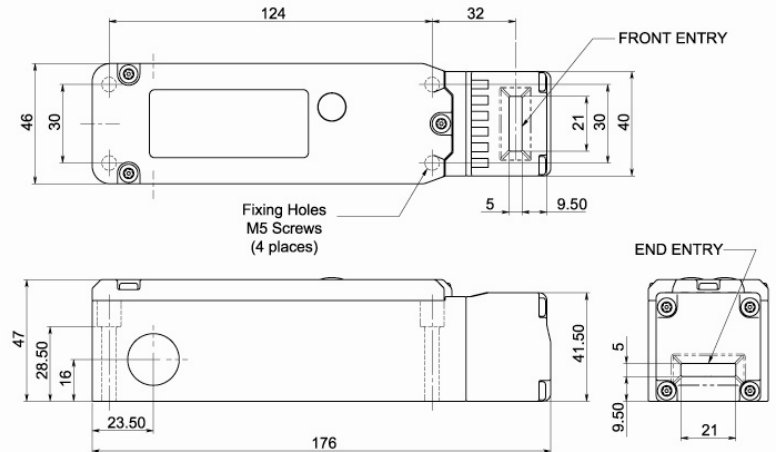

Information with regard to UL Standards: Type 1 enclosure.
 Maximum temperature 40°C.
 Use 16-28AWG stranded copper conductors (rated 90°C).
 Terminal Torque 6 lb ins. (0.7Nm).
 Intended for same polarity use. A300 Pilot Duty. 240V. 3A.
 PF 0.38 or greater, tested for 6,000 cycles endurance
 Use one polymeric conduit connection.
 Not suitable for connection to rigid metal conduit.

Original Instructions.

To request this data sheet in other languages please contact info@idemsafety.com
 Um dieses Datenblatt in Deutscher Sprache wenden Sie sich bitte anfordern info@idemsafety.com
 Pour obtenir cette fiche en Français, veuillez contacter info@idemsafety.com
 Para solicitar esta hoja de datos en Español, por favor contacto con info@idemsafety.com



WARNING: DO NOT DEFEAT, TAMPER, OR BYPASS THE SAFETY FUNCTION. FAILURE TO DO SO CAN RESULT IN DEATH OR SERIOUS INJURY.

AVERTISSEMENT: NE PAS DESACTIVER, MODIFIER, RETIRER, OU CONTOURNER CETI INTERVERROUILLAGE IL PEUT EN RESULTER DES BLESSURES GRAVES DU PERSONNEL UTILISATEUR.