

QA70HLS / QA100HLS



PRODUCT SPECIFICATION

QA70HLS | QA100HLS

Materials Lens-PC, Housing-ABS+GF(QA70HLS), ABS(QA100HLS)

Ambient operating temperature -30°C to +50°C

Protection rating IP66

Vibration resistant and shock-proof
can withstand 15g of vibration and 50g of shock

- Strong signal light emission in outdoor environment with strong sunlight by applying special LED diffusion system
- Excellent vibration and shock resistant structure for superior durability
- Fully enclosed structure that can withstand storm and severe dust environments (IP66)



QA70HLS



QA100HLS

QA70HLS LED Strobe Beacons

Model number	Voltage	Current	Certificates	Weight	Color
QA70HLS	DC12V-24V	Max.650mA	-	0.23kg	● R-Red ● A-Amber

- Mountable with two bolts on the main structure of the warning light for convenient assembly
- Suitable for small agricultural machines
- Flashing rate: 45-55 flashes/min, Outer diameter: 70mm
- ※ DC type model has a free-voltage range of 10V-30V.

QA100HLS LED Strobe Beacons

Model number	Voltage	Current	Certificates	Weight	Color
QA100HLS	DC12V-24V	Max.1.2A	CE	0.39kg	● R-Red ● A-Amber

- Flashing rate: 60-80 flashes/min, Outer diameter: 100mm
- ※ DC type model has a free-voltage range of 10V-30V.

Technical Diagram

Units: mm

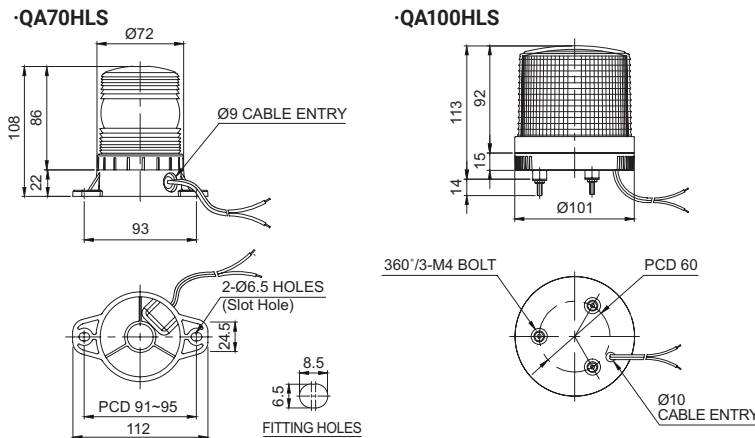

Wiring Instructions

- QA70HLS: External power line - UL1015 AWG18(0.75sq) x 2C 400mm
- QA100HLS: External power line - KSC3304(0.85sq) x 2C 400mm
- This product can be wired regardless of polarity.

Ordering Specification

QA100HLS	-	12/24	-	R
[Model number]		[Voltage]		[Color]
QA70HLS QA100HLS		12/24-DC12V-24V		● R-Red ● A-Amber