

Kobra – Tongue Switches with Guard Locking – Type KLTM-P2L

Data Sheet

KLTM-P2L

Power to Lock

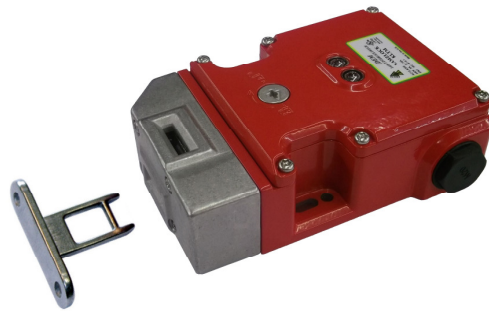

IMPORTANT NOTE:

Read and understand these instructions before installing, operating, or maintaining this equipment.

The product is designed to be a component of a customised safety orientated control system. It is the responsibility of the user to ensure the correct overall functionality of its systems and machines. IDEM, its subsidiaries and affiliates, are not in a position to guarantee all of the characteristics of a given system or product not designed by IDEM.

Application:

Tongue operated Solenoid Interlock switches are designed to fit to the leading edge of sliding, hinged or lift off machine guards to provide positively operated switching contacts and provide a tamper resistant key mechanism.

They are designed to provide robust position interlock detection for moving guards and will remain locked until the solenoid voltage is removed from the switch.

IMPORTANT: Any hazardous motion has to be controlled and a safe condition initiated in the event of power failure.

P2L versions (power to lock) may not be suitable for machines with a running down time.

Operation:

The switch is rigidly mounted to the frame of the guard or machine. The actuator is fitted to the moving part (frame) of the guard and is aligned to the switch entry aperture. The actuator profile is designed to match a cam mechanism within the switch head and provides a positively operated not easily defeatable interlock switch. When the actuator is inserted into the switch the safety contacts will close only when power is applied to the solenoid. This will then allow the machine start circuit to be enabled. When the solenoid power is removed the safety contacts are opened and the machine circuit is broken.

Installation:

- Installation of all IDEM interlock switches must be in accordance with a risk assessment for the individual application. Installation must only be carried out by competent personnel and in accordance with these instructions.
- M5 mounting bolts must be used to fix the switch and actuator, the tightening torque to ensure reliable fixing is 4.0 Nm. Tightening torque for the lid screws, conduit entry plugs and cable glands must be 1.5 Nm to ensure IP seal. Only use the correct size gland for the conduit entry and cable outside diameter. Tightening torque for the connection terminal screws is 0.7 Nm, max conductor size is 1.0 sq.mm.
- Always fit a mechanical stop to the guard to prevent damage to the front of the switch. Set the actuator gap to 3mm when the guard is closed and against the stop, (See Fig.A). Use alignment guides to ensure that the actuator enters the switch without interfering with the sides of the switch aperture. Always fit the aperture plug to the unused entry aperture to prevent debris entering the switch mechanism.
- Always use the circuits 11-12 and 21-22 to ensure monitoring of the lock.
- After installation check operation of all control circuits and the locking function. LED 1 will illuminate when power is applied to A1 and A2 (solenoid feed).

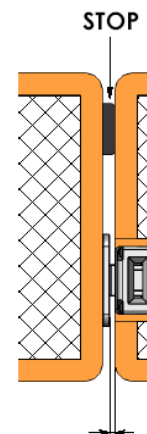

3mm Fig. A

Internal Terminal Connections:

A1	0V dc	
A2	24V dc	
11-12	Safety Circuit 1	(Closed when guard is closed and solenoid energised)
21-22	Safety Circuit 2	(Closed when guard is closed and solenoid energised)
33-34	Signal Circuit Guard	(Closed when Guard is closed)
43-44	Signal Circuit Guard	(Closed when Guard is open)

LED Function:

Green Solenoid Energised

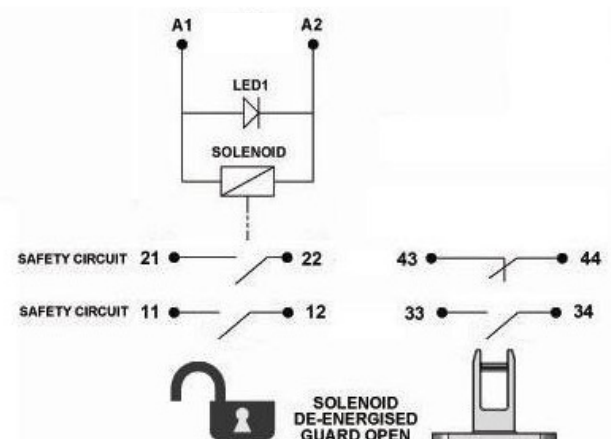

Kobra – Tongue Switches with Guard Locking – Type KLTM-P2L

IMPORTANT

The Risk Assessment for the particular application should include the risk of spare actuators. Spare actuators should not be readily available and must be securely controlled. Application consideration must be given to the fixing of the actuator which has to be in a way that prevents disassembly by easy means.

Ensure that the switch holding force (Fzh) is sufficient to withstand the static forces applied during normal use and dynamic effects caused by bouncing of the guard shall not create an impact reaction force which exceeds the holding force. If the expected impact reaction forces are higher than the specified holding force for the switch, then design measures must be applied to avoid the force.

The safety functions and mechanics must be tested regularly. For applications where infrequent guard access is foreseeable, the system must have a manual function test to detect a possible accumulation of faults. At least once per month for PLe Cat3/4 or once per year for PLd Cat3 (ISO13849-1). Where possible it is recommended that the control system of the machine demands and monitors these tests, and stops or prevents the machine from starting if the test is not done. (See ISO14119).

Maintenance:

Every Week: Check the switch actuator and body for signs of mechanical damage and wear. Replace any switch showing damage.

Every 6 Months: Check for mechanical damage to switch body or actuator. Isolate power and remove cover.

Check screw terminal tightness and check for signs of moisture ingress.

Never attempt to repair any switch. Replace any switch displaying damage.

These requirements form part of the product warranty.

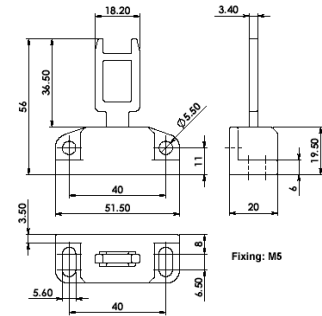
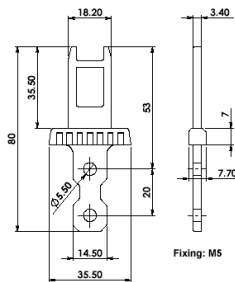
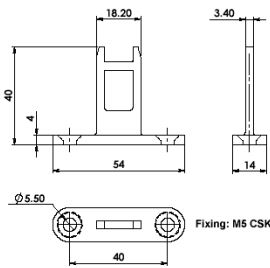

Conforming to Standard: ISO14119, IEC 60947-5-1, UL60947-5-1, ISO13849-1

Safety Classification and Reliability Data:

Mechanical Reliability B10d
ISO 13849-1
EN 62061

Safety Data - Annual Usage
PFHd
Proof Test Interval (Life)

35 years

MTTFd
356 years

Solenoid Voltage (by part number)
24V ac/dc (12W.)

Safety Contacts 11/12 21/22 33/34
Utilization Category AC15 A300 3A.

Thermal Current (Ith) 5A

Overload protection fuse (fuse externally)
10A. (FF).

Auxiliary Contact 43/44
230V.ac/dc 0.5A. Maximum.

Rated Insulation Voltage
600VAC

Rated Impulse Withstand Volt
2500VAC

Travel for Positive Opening
10mm

Approach Speed
200mm/m. to 1000mm/s.

Man. Actuation Frequency
2 cycle/sec

Actuator entry minimum radius
175mm Standard 100mm Flexible

Case Material
Die Cast painted red

Head Material
Stainless Steel 316

Actuator Material
Stainless steel 316

Enclosure Protection
IP67

Operating Temperature
-25°C to 40°C

Holding Force
F1Max: 3000N. Fzh: 2307N.

Vibration
IEC 68-2-6, 10-55Hz+1Hz,

Excursion: 0.35mm, 1 octave/min

Conduit Entry
Various (See Sales Part Numbers)

Fixing
4 x M5

Actuator insertion

8.0 6.0 0 mm

11/12	Open	
21/22	Open	
43/44	Closed	

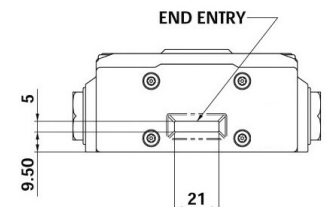
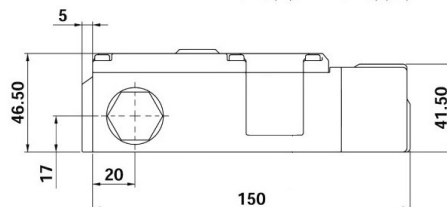
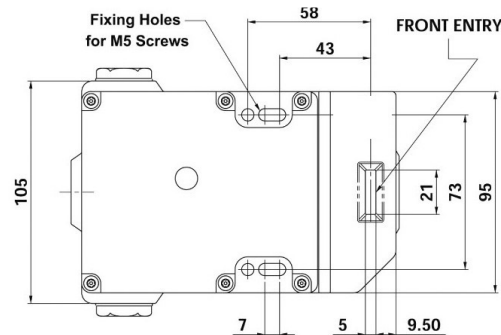

Information with regard to UL Standards: Type 1 enclosure.

Maximum temperature 40°C.

Use 16-28AWG stranded copper conductors (rated 90°C).

Terminal Torque 6 lb ins. (0.7Nm).

Intended for same polarity use. A300 Pilot Duty. 240V. 3A.

PF 0.38 or greater, tested for 6,000 cycles endurance

Use one polymeric conduit connection.

Not suitable for connection to rigid metal conduit.



WARNING: DO NOT DEFEAT, TAMPER, OR BYPASS THE SAFETY FUNCTION. FAILURE TO DO SO CAN RESULT IN DEATH OR SERIOUS INJURY.

AVERTISSEMENT: NE PAS DESACTIVER, MODIFIER, RETIRER, OU CONTOURNER CETI INTERVERROUILLAGE IL PEUT EN RESULTER DES BLESSURES GRAVES DU PERSONNEL UTILISATEUR.

Original Instructions.

To request this data sheet in other languages please contact info@idemsafety.com

Um dieses Datenblatt in Deutscher Sprache wenden Sie sich bitte anfordern info@idemsafety.com

Pour obtenir cette fiche en Français, veuillez contacter info@idemsafety.com

Para solicitar esta hoja de datos en Español, por favor contacto con info@idemsafety.com