

LED Strobe Beacons for Heavy-Duty Equipment

QA115HLS / QA115HLSP

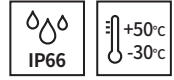

Adopted Qlight's new developed light diffusion system.

PRODUCT SPECIFICATION

QA115HLS | QA115HLSP

Materials Lens-PC, Housing-PC
Ambient operating temperature -30°C to +50°C
Protection rating IP66
Vibration resistant and shock-proof
 can withstand 15g of vibration and 50g of shock

- Strong signal light emission in outdoor environment with strong sunlight by applying special LED diffusion system
- Ability to compensate for signal attenuation phenomenon that occurs during daytime operation with a powerful xenon lamp.
- Can select between pole mount and direct mount type to fit your application needs.



QA115HLS



QA115HLSP

QA115HLS / QA115HLSP LED Strobe Beacons

Model number	Voltage	Current	Certificates	Weight	Color
QA115HLS	DC12V-24V	Max.820mA	CE	1.06kg	● R-Red
QA115HLSP				1.22kg	● A-Amber

- Pole mount type model consists of a shock-proof rubber body; this feature provides excellent durability to vibration and shock
- Flashing rate: 60-80 flashes/min
- ※ DC type model has a free-voltage range of 10V-30V.

Technical Diagram

Units: mm

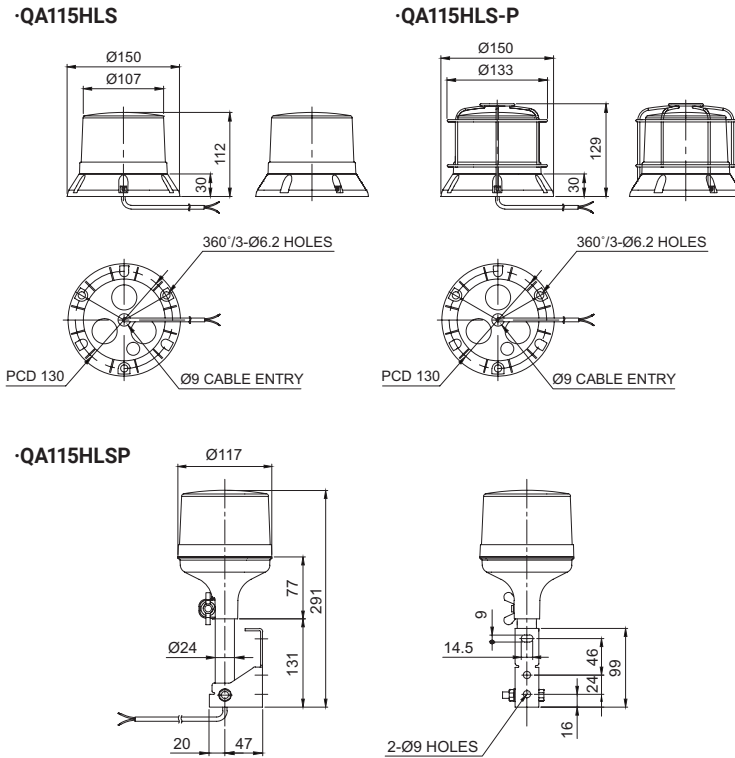

Wiring Instructions

- External power line
UL2464 18AWG x 2C 400mm
- This product can be wired regardless of polarity.

Ordering Specification

QA115HLSP	-	12/24	-	R
[Model number]		[Voltage]		[Color]
QA115HLS QA115HLSP		12/24-DC12V-24V		● R-Red ● A-Amber

Customization

- User selected connector type available upon request
- Built-in protection cage (QA115HLS-P)