

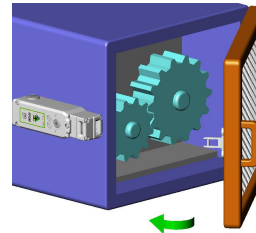

Safety Interlock Switch with Guard Locking

KLP-P2L Operating Instructions

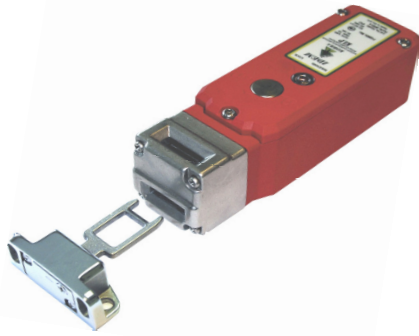

Hinged Guard

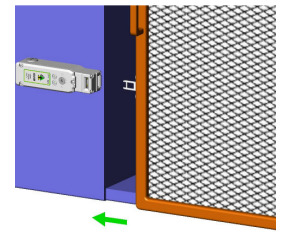

Sliding Guard

IMPORTANT NOTE:

Read and understand these instructions before installing, operating, or maintaining this equipment.

The product is designed to be a component of a customised safety orientated control system. It is the responsibility of the user to ensure the correct overall functionality of its systems and machines. IDEM, its subsidiaries and affiliates, are not in a position to guarantee all of the characteristics of a given system or product not designed by IDEM.

Application and Operation:

The switch is rigidly mounted to the frame of the guard or machine. The actuator is fitted to the moving part (frame) of the guard and is aligned to the switch entry aperture. The actuator profile is designed to match a cam mechanism within the switch head and provides a positively operated not easily defeatable interlock switch. When the actuator is inserted into the switch the safety contacts will close only when power is applied to the solenoid. This will then allow the machine start circuit to be enabled. When the solenoid power is removed the safety contacts are opened and the machine circuit is broken.

IMPORTANT: Any hazardous motion has to be controlled and a safe condition initiated in the event of power failure.

P2L versions (power to lock) may not be suitable for machines with a running down time.

Installation:

- Installation of all interlock switches must be in accordance with a risk assessment for the individual application. Installation must only be carried out by competent personnel and in accordance with these instructions.
- M5 mounting bolts must be used to fix the switch and actuator, the tightening torque to ensure reliable fixing is 4.0 Nm. **To prevent loosening of the switch after installation, always fix the M5 mounting bolts with a thread-locking compound or secure using self locking nuts.**
Tightening torque for the lid screws, conduit entry plugs and cable glands must be 1.5 Nm to ensure IP seal. Only use the correct size gland for the conduit entry and cable outside diameter.
Tightening torque for the connection terminal screws is 0.7 Nm, max conductor size is 1.0 sq.mm.
The switch head position can be selected by removing the actuator, loosening the 4 head bolts and then rotating the head to the position required. Re-tighten the head bolts and then check actuator insertion and withdrawal.
Tightening torque for the head bolts is 1.5Nm.
- Always fit a mechanical stop to the guard to prevent damage to the front of the switch.
Set the actuator gap to 3mm when the guard is closed and against the stop. (See Fig. A.)
Use alignment guides to ensure that the actuator enters the switch without interfering with the sides of the switch aperture.
Always fit the aperture plug to the unused entry aperture to prevent debris entering the switch mechanism.
- After installation check operation of all control circuits and the locking function.
For applications with a run down time after removing power, ensure that the correct timing allowance has elapsed before energising the solenoid.
LED 1 GREEN will illuminate when power is applied to A1 and A2 (solenoid feed).

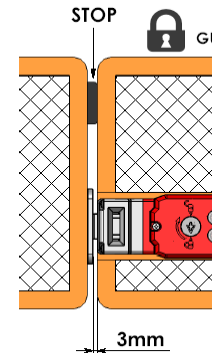
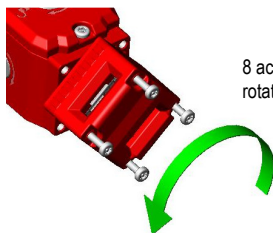

Fig. A



8 actuator entry positions rotatable head

Internal Terminal Connections:

- A1 0V dc
- A2 24V.dc
- 11-12 Safety Circuit 1 – (must always be used)
- 21-22 Safety Circuit 2
- 33-34 Signal Circuit Guard - (Closed when Guard is closed)
- 43-44 Signal Circuit Guard - (Closed when Guard is open)

LED Function:

- Green Solenoid Energised

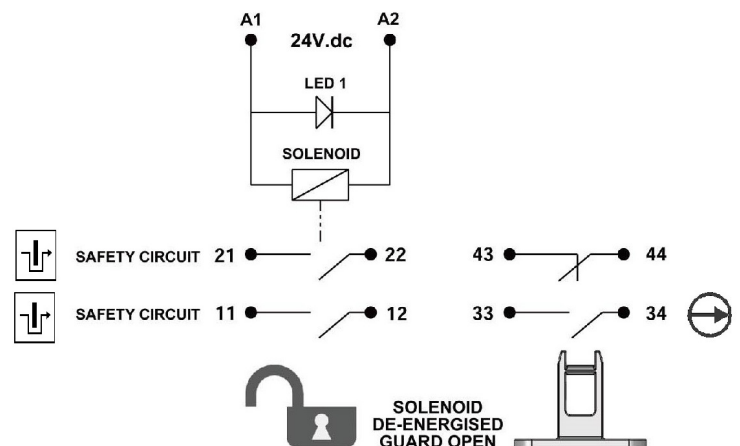

Safety Interlock Switch with Guard Locking

IMPORTANT

The Risk Assessment for the particular application should include the risk of spare actuators. Spare actuators should not be readily available and must be securely controlled. Application consideration must be given to the fixing of the actuator which has to be in a way that prevents disassembly by easy means.

Ensure that the switch holding force (Fzh) is sufficient to withstand the static forces applied during normal use and dynamic effects caused by bouncing of the guard shall not create an impact reaction force which exceeds the holding force. If the expected impact reaction forces are higher than the specified holding force for the switch, then design measures must be applied to avoid the force.

The safety functions and mechanics must be tested regularly. For applications where infrequent guard access is foreseeable, the system must have a manual function test to detect a possible accumulation of faults. At least once per month for PLe Cat3/4 or once per year for PLD Cat3 (ISO13849-1). Where possible it is recommended that the control system of the machine demands and monitors these tests, and stops or prevents the machine from starting if the test is not done. (See ISO14119).

Maintenance:

Every Month: Check the switch actuator and body for signs of mechanical damage and wear. Replace any switch showing damage.

Every 6 Months: Check for mechanical damage to switch body or actuator. Isolate power and remove cover.

Check screw terminal tightness and check for signs of moisture ingress.

Never attempt to repair any switch. Replace any switch displaying damage.

These requirements form part of the product warranty.

Quick Connect (QC) M23 12 way Male Plug (Pin view from switch)	Switch Circuit
1 3	A1 A2
4 6	11 / 12
7 8	21 / 22
2 5	43 / 44
9	33
10	34
Earth	12

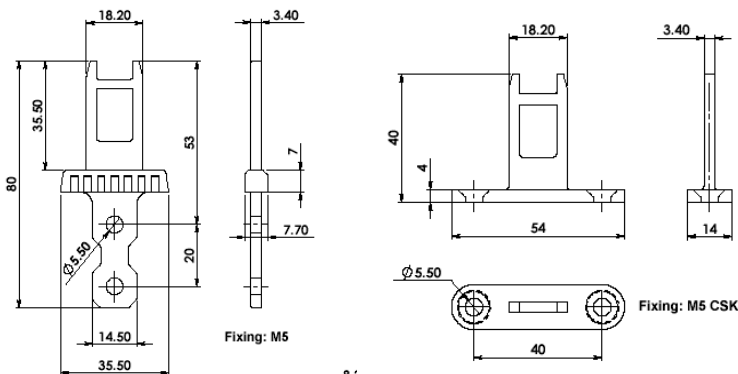
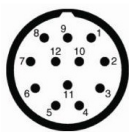

Conforming to Standard: ISO14119, IEC60947-5-1, UL60947-5-1, ISO13849-1

Safety Classification and Reliability Data:

Mechanical Reliability B10d

ISO 13849-1

EN 62061

Safety Data - Annual Usage

Solenoid Voltage (by part number)

Safety Contacts 11/12 21/22 33/34

Overload protection fuse (fuse externally)

Auxiliary Contact 43/44

Rated Insulation Voltage

Rated Impulse Withstand Volt

Travel for Positive Opening

Approach Speed

Man. Actuation Frequency

Actuator entry minimum radius

Case Material

Head Material

Actuator Material

Enclosure Protection

Operating Temperature

Holding Force

Vibration

Conduit Entry

Fixing

2.5 x 10⁶ operations at 100mA load

up to PLe / Cat.4 depending upon system architecture

up to SIL3 depending upon system architecture

8 cycles per hour / 24 hours per day / 365 days

MTTFd 356 years

24V ac/dc (12W.)

Utilization Category AC15 A300 3A.

Thermal Current (Ith) 5A

10A. (FF).

230V.ac/dc 0.5A. Maximum.

600VAC

2500VAC

10mm

200mm/m. to 1000mm/s.

2 cycle/sec

175mm Standard 100mm Flexible

Glass Filled Polyester

Stainless Steel 316

Stainless steel 316

IP67

-25°C to 40°C

F1Max: 2000N. Fzh: 1538N.

IEC 68-2-6, 10-55Hz+1Hz,

Excursion: 0.35mm, 1 octave/min

Various (See Sales Part Numbers)

4 x M5

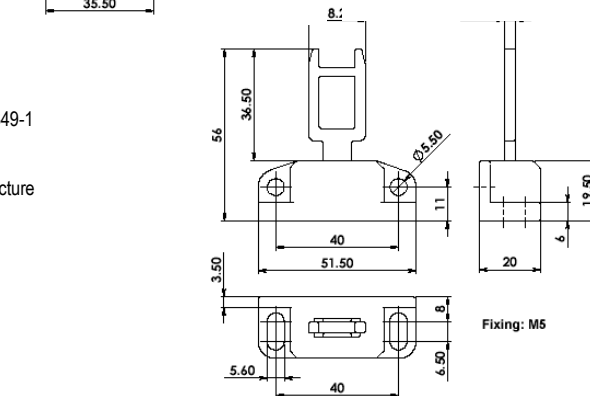

Actuator insertion (mm)

6.0 5

11/12	Open	Solenoid energised
21/22	Open	Solenoid energised
33/34	Open	Tongue Inserted
43/44	Open	Tongue Inserted

Contact 33/34 is positively operated at withdrawal of actuator

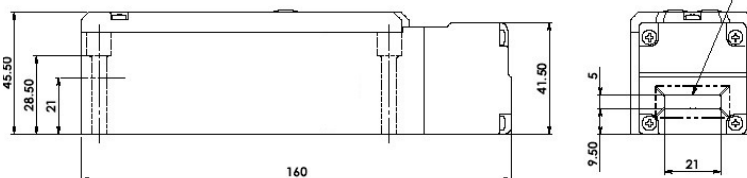
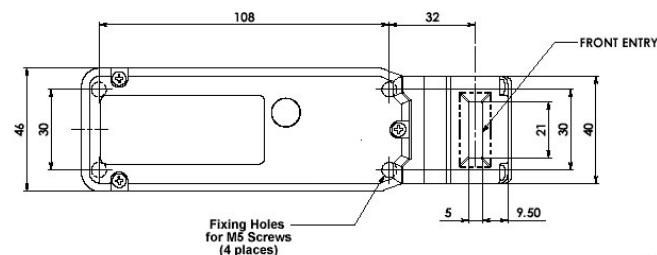

Information with regard to UL Standards: Type 1 enclosure.

Maximum temperature 40°C.

Use 16-28AWG stranded copper conductors (rated 90°C).

Terminal Torque 6 lb ins. (0.7Nm).

Intended for same polarity use. A300 Pilot Duty. 240V. 3A.

PF 0.38 or greater, tested for 6,000 cycles endurance

Use one polymeric conduit connection.

Not suitable for connection to rigid metal conduit.



WARNING: DO NOT DEFEAT, TAMPER, OR BYPASS THE SAFETY FUNCTION. FAILURE TO DO SO CAN RESULT IN DEATH OR SERIOUS INJURY.

AVERTISSEMENT: NE PAS DESACTIVER, MODIFIER, RETIRER, OU CONTOURNER CETI INTERVERROUILLAGE IL PEUT EN RESULTER DES BLESSURES GRAVES DU PERSONNEL UTILISATEUR.

Original Instructions.

To request this data sheet in other languages please contact info@idemsafety.com
Um dieses Datenblatt in Deutscher Sprache wenden Sie sich bitte anfordern info@idemsafety.com
Pour obtenir cette fiche en Français, veuillez contacter info@idemsafety.com
Para solicitar esta hoja de datos en Español, por favor contacto con info@idemsafety.com