

KOBRA - Tongue Operated Switch Type: K-15

FEATURES:

The K-15 Safety Interlock switch is designed to provide position interlock detection for moving guards.

They are designed to fit to the leading edge of sliding, hinged or lift off machine guards.

They offer a compact 86mm long body to fit to applications where space is restricted, yet offer 3 pole contacts and choice of 3 conduit entries for wiring versatility.

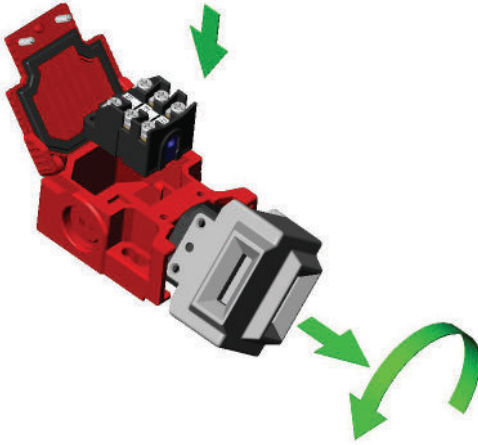

The head can be rotated to give 4 actuator entry positions. Designed with a hinged lid to fit replaceable contact blocks. Flexible actuators are available and the K-15 is available with a Stainless Steel head.

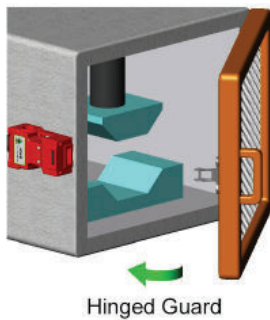

Hinged Guard

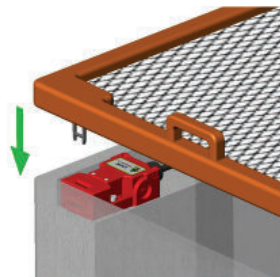

Lift Off Guard



Sliding Guard

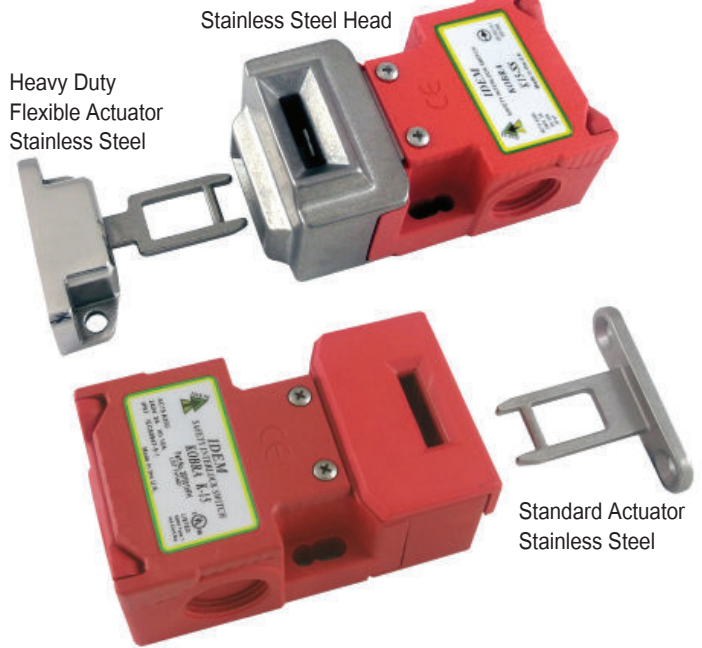

Stainless Steel Head

Heavy Duty
Flexible Actuator
Stainless Steel

Standard Actuator
Stainless Steel

DIMENSIONS:

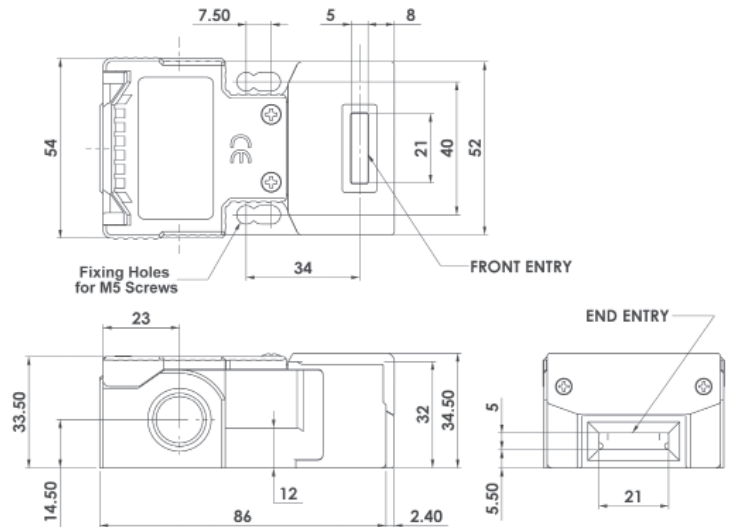

Standards: ISO14119 EN60947-5-1 EN60204-1
ISO13849-1 EN62061 UL508

Safety Classification and Reliability Data:

Mechanical Reliability B10d	2.5 x 10 ⁶ operations at 100mA load
ISO13849-1	Up to PLe depending upon system architecture
EN62061	Up to SIL3 depending upon system architecture
Safety Data – Annual Usage	8 cycles per hour/24 hours per day/365 days
	MTTFd 356 years
Utilization Category	AC15 A300 3A
Thermal Current (Ith)	10A
Rated Insulation/Withstand Voltages	500Vac/2500Vac
Travel for Positive Opening	8mm
Actuator Entry Minimum Radius	175mm Standard 100mm Flexible
Maximum Approach/Withdrawal Speed	600mm/s
Body Material	Polyester
Head Material	Polyester or Stainless Steel 316
Enclosure Protection	IP67
Operating Temperature	-25C +80C
Vibration	IEC 68-2-6 10-55Hz + 1Hz
	Excursion 0.35mm 1 octave/min
Conduit Entry	Various (See Sales Number)
Fixing	2 x M5

KOBRA - Tongue Operated Switch Type: K-15

ACTUATOR OPTIONS (see p100)

CONTACT BLOCK OPTIONS:

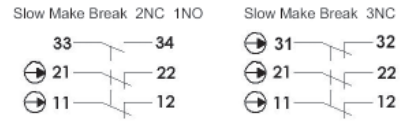
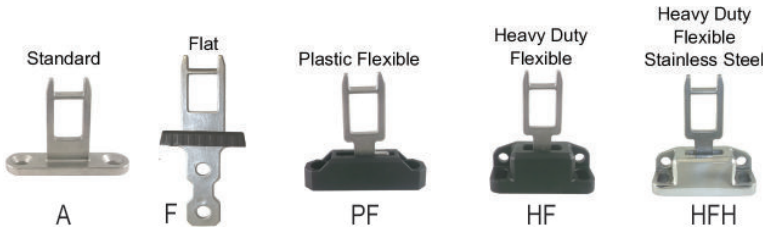

ACCESSORIES (see p100-101)

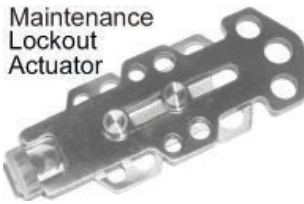

Fits to switch aperture during maintenance and provides multiple padlock holes.



Flat Actuator supplied with 300mm (12") chain. Can be used where poor alignment exists and provides manual insertion of actuator by operator.



2 colour LED (3 wires) Steady Red and Steady Green. Fits to conduit entry and provides option for LED indication based upon switch contacts.

APPLICATION EXAMPLE

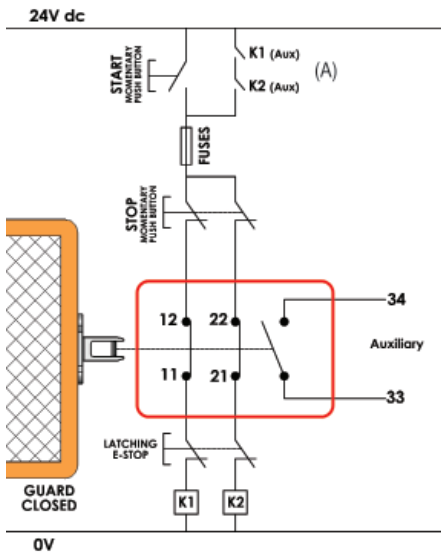

Guard Door Interlocked - Dual Channel (Non Monitored)

This system shows interlock switch circuits in position (A) 11-12 and 21-22 configured to allow direct feed to contactor coils K1 and K2.

This provides Dual Channel wiring and a check of the contactor feedback circuits through the auxiliary contacts (A) of K1 and K2.

Opening the interlock switch or depressing the Emergency Stop will isolate power to the contactor coils.

Re-start can only occur providing the Guard is closed, and the Emergency Stop is reset.

The system is shown with the Machine Stopped, the Guard Closed and the contactors able to be energised.

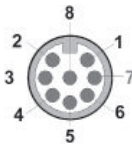

Switch Circuit	Quick Connect (QC) M12 8 Way Male (on Flying Lead 250mm) Pin View from Switch
11/12	1 7
21/22 or 23/24	6 5
33/34 or 31/32	4 3



FEMALE QC LEADS	LENGTH	SALES NUMBER
M12 8 Way	5m (15ft)	140101
M12 8 Way	10m (30ft)	140102

SALES NUMBER	CONTACTS	M20	1/2" NPT	QC M12 8 WAY
K-15 Switch	2NC 1NO	207001	207002	207008
K-15 Switch	3NC	207004	207005	207009
Actuator	Standard	Add A	to Sales Part Number	
Actuator	Flat	Add F	to Sales Part Number	
Actuator	Plastic Flexible	Add PF	to Sales Part Number	
Actuator	Heavy Duty Flexible	Add HF	to Sales Part Number	
Actuator	Heavy Duty S/Steel	Add HFH	to Sales Part Number	
Stainless Steel Head Version		Add SS to Sales Part Number		
Actuator Holding 40N		Add 40N to Sales Part Number		

Ordering example: Kobra K-15 M20 2NC 1NO with Standard Actuator and Stainless Steel Header Sales Number: 207001-A-SS
 Gold Plated Contacts available for low power circuits (5V 5mA).
 Add GC to Sales Number e.g. 207001-A-GC
 Also available with 3NO Contacts for use as indication purposes only.
 Please contact us for further information.