

S300 PA



ADVANCED MAXI PHOTOELECTRIC MULTIVOLTAGE SENSORS

- Industrial plastic housing with IP67 mechanical protection
- Timing function from 0.6-16 s ON delay, OFF delay and ONE SHOT
- Terminal block for both Vdc and Vac/ Vdc free voltage
- Distance trimmer for mechanical background suppression models

APPLICATIONS

- Packaging end of line, palletizers
- Outdoor or indoor gates control
- Manufacturing plants



(*)DC models:
ATEX II 3DG

S300 PA		
Through beam	0...50 m	
Retroreflective (on R2 reflector)	0,1...15 m	
Polarized retroreflective	0,1...10 m	
Diffuse proximity	0,05...2 m	
Background suppression	0,2...2 m	
Power supply	Vdc	12...30 V
	Vac	
	Vac/dc	24...240 Vac/24...60 Vdc
Output	PNP	
	NPN	
	NPN/PNP	•
	relay	•
Connection	other	
	cable	
	connector	•
	pig-tail	
Approximate dimensions (mm)	25x100x70	
Housing material	PBT	
Mechanical protection	IP67	

TECHNICAL DATA

Power supply	12 ... 30 Vdc (mod. S300...2) 24...240 Vac/24...60 Vdc (mod. S300...1)
Ripple	10% max.
Consumption (output current excluded)	35 mA max. (mod. S300...2) 3 VA max. (mod. S300...1)
Light emission	red LED 660 nm (mod. S300...B) IR LED 940 nm (mod. S300...C) IR LED 880 nm (mod. S300...A/G/M)
Setting	sensitivity trimmer (mod. S300...A/B/C/F), DARK/LIGHT dip-switch (mod. S300...A/B/C/F/M) 7-turns distance adjustment trimmer (mod. S300...M) dip-switch mode ON delay/OFF delay/ON-OFF delay/single pulse (ONE-SHOT) (mod. S300...x06) timing trimmer (mod. S300...x06)
Indicators	yellow OUTPUT LED (excl. mod. S300...G) green STABILITY LED, POWER LED (mod. S300...G)
Output	PNP or NPN open collector (mod. S300...2); electromechanical SPDT 250 Vac/30 Vdc (mod. S300...1)
Output current	100 mA (mod. S300...2) 3 A max. (mod. S300...1)
Saturation voltage	2,4 V max.
Response time	1 ms (mod. S300..2-A/B/C/M) 2 ms (mod. S300..2-F/G) 25 ms (mod. S300...1)
Switching frequency	500 Hz (mod. S300..2-A/B/C/M) 250 Hz (mod. S300..2-F/G) 20 Hz max. (mod. S300...1)
Connection	terminal block
Dielectric strength	500 Vac, 1 min between electronics and housing
Insulating resistance	>20 MΩ, 500 Vdc between electronics and housing
Electrical protection	class 2 (mod. S300...2)
Mechanical protection	IP67 (IEC/EN60529)
Ambient light rejection	according to EN 60947-5-2
Vibrations	0,5 mm amplitude, 10 ... 55 Hz frequency, for every axis (EN60068-2-6)
Shock resistance	11 ms (30 G) 6 shock for every axis (EN60068-2-27)
Housing material	PBT 30% glass fiber-reinforced
Lens material	frontal window and lens in PC
Operating temperature	-25 ... 55 °C
Storage temperature	-25 ... 70 °C
Weight	120 g (mod. S300...2), 130 g (mod. S300...1)

DIMENSIONS

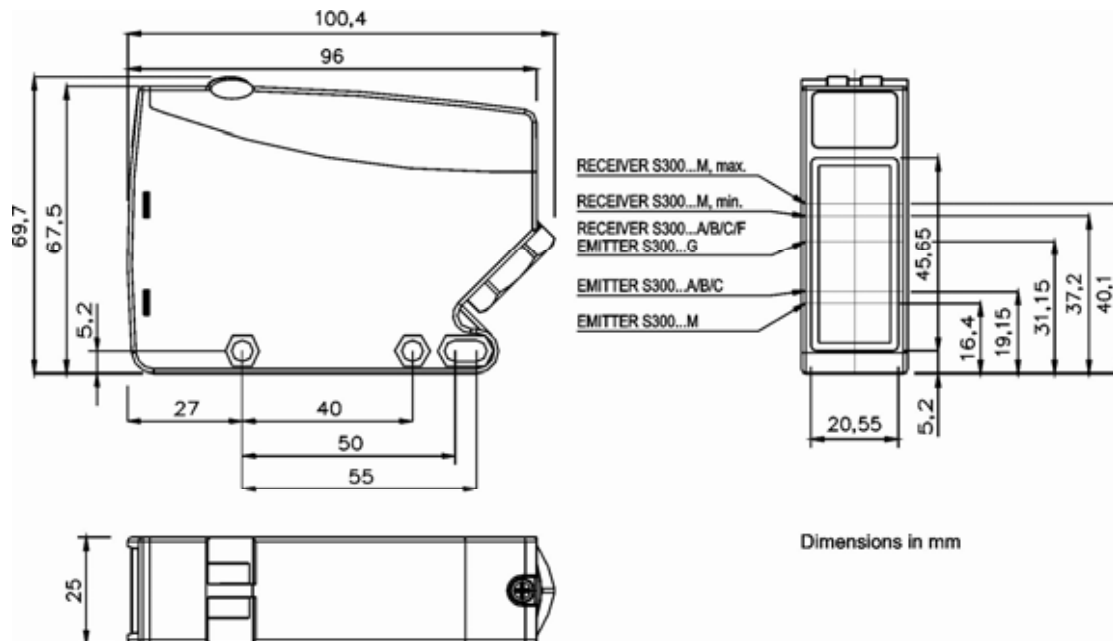

CONNECTIONS

VAC MODELS

Through beam emitter

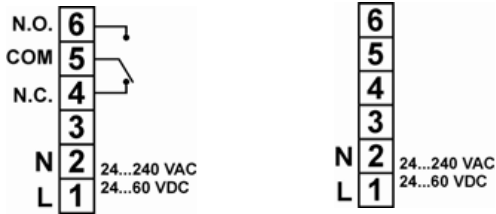

VDC MODELS

Through beam emitter

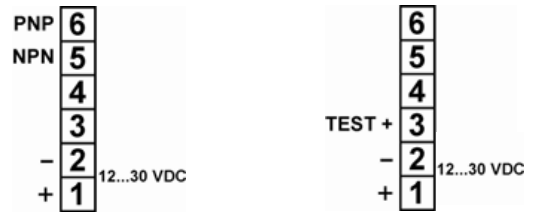

INDICATORS AND SETTINGS

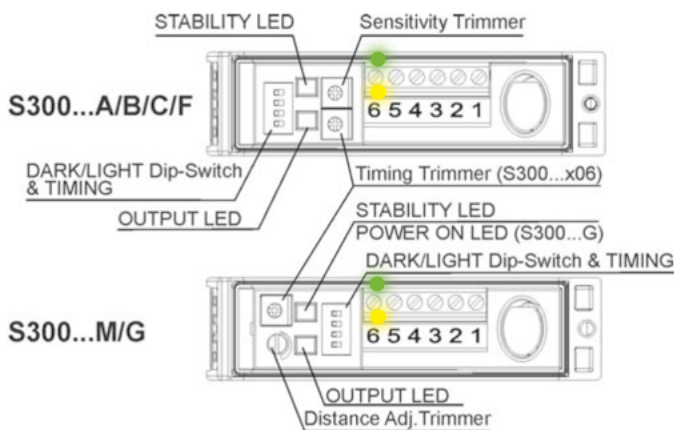

Settings

The M model presents a **multiturn adjustment screw** for the adjustment of the background suppression distance using a mechanical variation of the optic triangulation angle. The **other models have a mono-turn electronic trimmer** that adjusts the sensitivity and the sensor operating distance. The operating distance can be increased by rotating the screws clockwise. Trimmers can be used to adjust the output activation and deactivation delay time whilst functioning mode selection is performed through DIP SWITCHES.

DETECTION DIAGRAMS

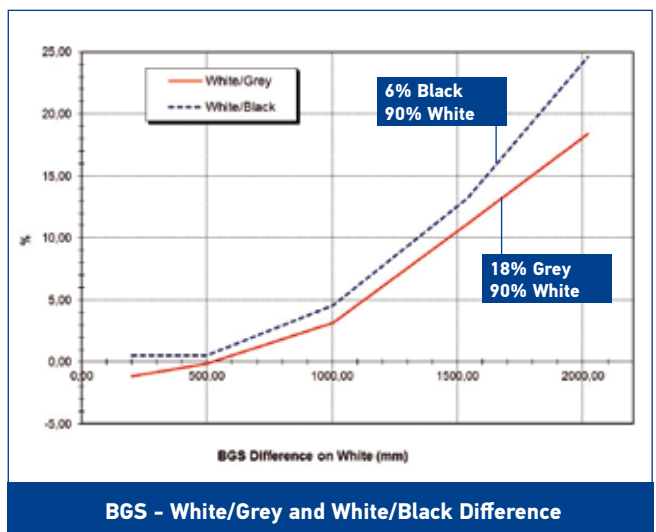
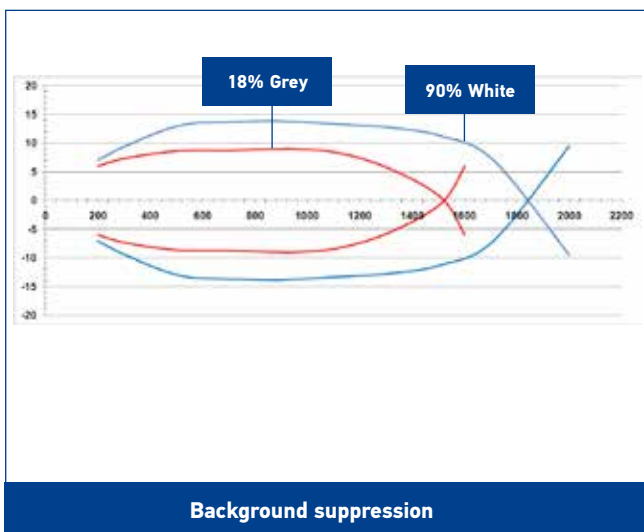
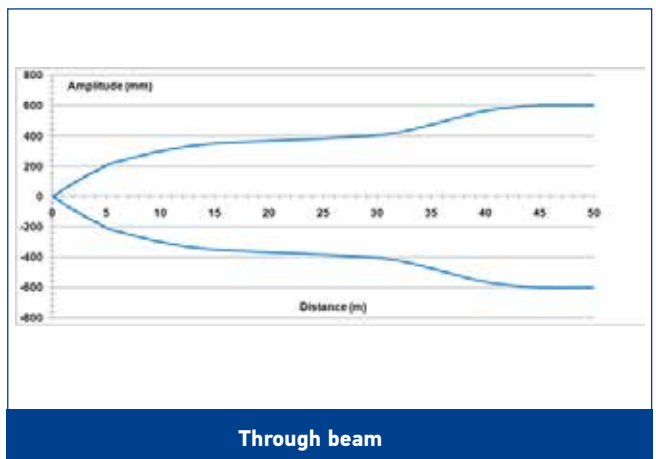
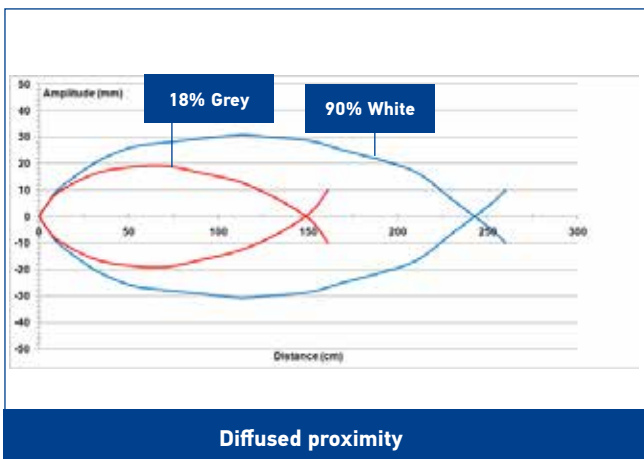
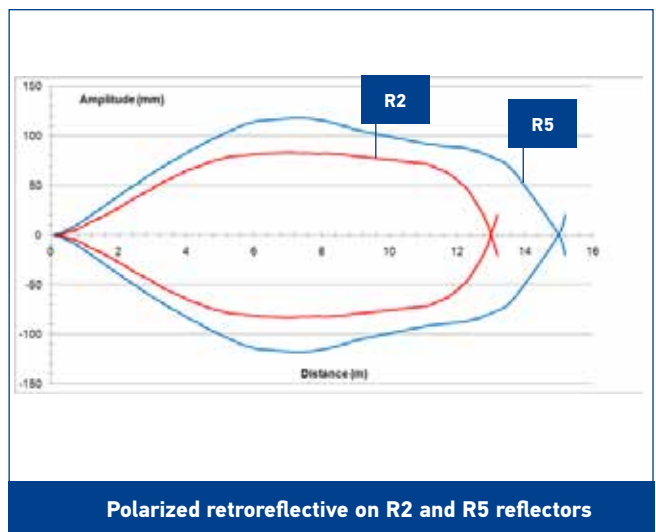
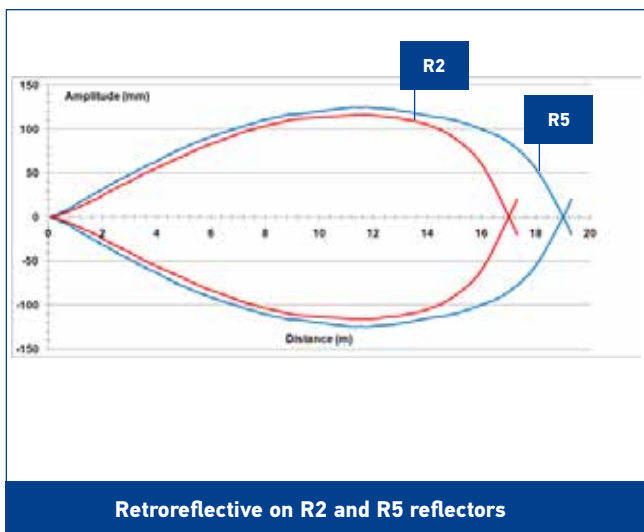

MODEL SELECTION AND ORDER INFORMATION

OPTIC FUNCTION	POWER SUPPLY	OUTPUT	SETTING	MODEL	ORDER No.
Retroreflective (IR LED 880 nm)	12...30 Vdc	NPN/ PNP	Sensitivity trimmer and D/L dip-switch	S300-PA-2-A01-OC	951451500
			Timing and sensitivity trimmers, D/L dip-switch	S300-PA-2-A06-OC	951451510
	24...240 Vac/24...60 Vdc	Relay	Sensitivity trimmer and D/L dip-switch	S300-PA-1-A01-RX	951451480
			Timing and sensitivity trimmers, D/L dip-switch	S300-PA-1-A06-RX	951451490
Polarized retroreflective (red LED 660 nm)	12...30 Vdc	NPN/ PNP	Sensitivity trimmer and D/L dip-switch	S300-PA-2-B01-OC	951451540
			Timing and sensitivity trimmers, D/L dip-switch	S300-PA-2-B06-OC	951451550
	24...240 Vac/24...60 Vdc	Relay	Sensitivity trimmer and D/L dip-switch	S300-PA-1-B01-RX	951451520
			Timing and sensitivity trimmers, D/L dip-switch	S300-PA-1-B06-RX	951451530
Diffused proximity (IR LED 940 nm)	12...30 Vdc	NPN/ PNP	Sensitivity trimmer D/L dip-switch	S300-PA-2-C01-OC	951451420
			Timing and sensitivity trimmers, D/L dip-switch	S300-PA-2-C06-OC	951451430
	24...240 Vac/24...60 Vdc	Relay	Sensitivity trimmer and D/L dip-switch	S300-PA-1-C01-RX	951451400
			Timing and sensitivity trimmers, D/L dip-switch	S300-PA-1-C06-RX	951451410
Through beam receiver	12...30 Vdc	NPN/ PNP	Sensitivity trimmer and D/L dip-switch	S300-PA-2-F01-OC	951451600
			Timing and sensitivity trimmers, D/L dip-switch	S300-PA-2-F06-OC	951451610
	24...240 Vac/24...60 Vdc	Relay	Sensitivity trimmer and D/L dip-switch	S300-PA-1-F01-RX	951451580
			Timing and sensitivity trimmers, D/L dip-switch	S300-PA-1-F06-RX	951451590
Through beam emitter (IR LED 880 nm)	12...30 Vdc	-	-	S300-PA-2-G00-EX	951451570
	24...240 Vac/24...60 Vdc		-	S300-PA-1-G00-EX	951451560
Background suppression (IR LED 880 nm)	12...30 Vdc	NPN/ PNP	7-turns distance adjustment trimmer and /L dip-switch	S300-PA-2-M01-OC	951451460
			Timing and 7-turns distance adj. trimmers, D/L dip-switch	S300-PA-2-M06-OC	951451470
	24...240 Vac/24...60 Vdc	Relay	7-turns distance adjustment trimmer and D/L dip-switch	S300-PA-1-M01-RX	951451440
			Timing and 7-turns distance adj. trimmers, D/L dip-switch	S300-PA-1-M06-RX	951451450

ACCESSORIES

ST-511

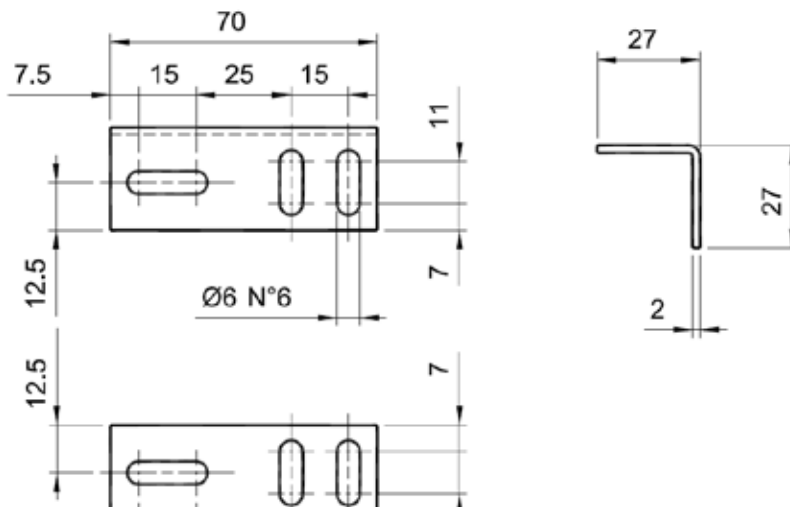

ST-S300-PA

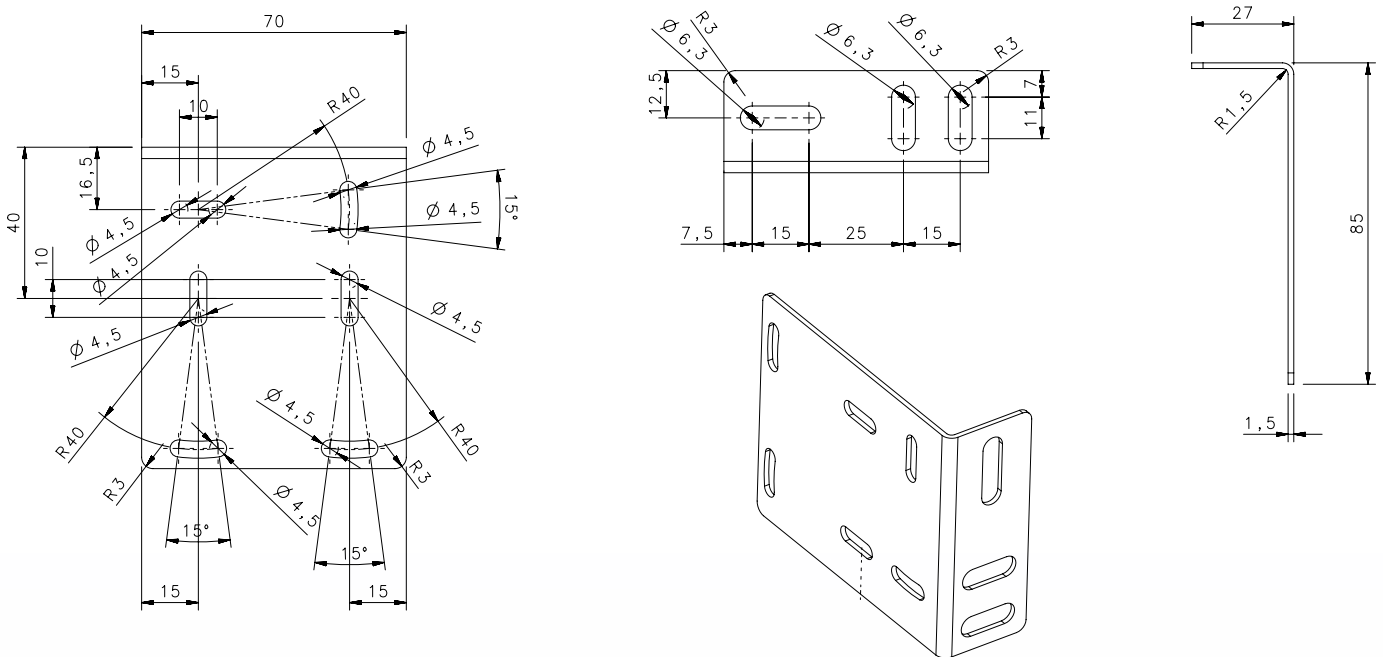

MODEL	DESCRIPTION	ORDER No.
ST-511	mounting bracket	95ACC2810
ST-S300-PA	mounting bracket	95ACC7870

S300 PR



HEAVY DUTY SENSOR FOR OUTDOOR APPLICATIONS AND HARSH ENVIRONMENTS

- Industrial plastic housing with IP67 mechanical protection
- Defogging system function
- Double independent timing functions with double time scale from 0-2s or 0-10s, One-Delay, Off Delay, ONE SHOT

APPLICATIONS

- Packaging end of line, palletizers
- Outdoor or indoor gates control
- Automotive plants
- Automated warehousing



(*)DC models: ATEX II 3DG

S300 PA		
Through beam	0...60 m	
Polarized retroreflective	0,1...22 m	
Diffuse proximity	0,05...5 m	
Background suppression	0,4...2,5 m	
Power supply	Vdc	10...30 V
	Vac	
	Vac/dc	24...240 Vac/24...60 Vdc
Output	PNP	
	NPN	
	NPN/PNP	•
	relay	•
	other	
Connection	cable	
	connector	•
	pig-tail	
Approximate dimensions (mm)	25x100x70	
Housing material	PBT	
Mechanical protection	IP67	

TECHNICAL DATA

Power supply	10 ... 30 Vdc (mod. S300...2/5) 24...240 Vac/24...60 Vdc (mod. S300...1)
Ripple	10% max.
Consumption (output current excluded)	30 mA max. (mod. S300...2/5-B/C) 35 mA max. (mod. S300...2/5-M) 25 mA max. (mod. S300...2/5-F) 20 mA max. (mod. S300...2/5-G) 3 VA max. (mod. S300...1) red LED 660 nm (mod. S300...B) IR LED 880 nm (mod. S300...C/G/M)
Light emission	sensitivity trimmer, DARK/LIGHT trimmer (mod. S300...F/C/B) 15 turns adjustment screw/DARK/LIGHT trimmer (mod. S300...M) emission power regulation trimmer (mod. S300...G)
Setting	versions with timing functions: time base selection and one shot trimmer/ON DELAY trimmer/OFF DELAY trimmer (mod. S300...x06)
Indicators	yellow OUTPUT LED (excl. mod. S300...G) green STABILITY LED, POWER LED (mod. S300...G)
Output	PNP or NPN open collector (mod. S300...2/5); Electromechanical SPDT 250 Vac/30 Vdc (mod. S300...1)
Output current	100 mA (mod. S300...2/5) 3 A max. (mod. S300...1)
Saturation voltage	2,4 V max.
Response time	1 ms (mod. S300...2/5-B/C/F/G) 2 ms (mod. S300...2/5-M) 20 ms (mod. S300...1)
Switching frequency	500 Hz (mod. S300...2/5-/B/C/F/G) 250 Hz (mod. S300...2/5-M) 25 Hz (mod. S300...1)
Connection	terminal block, M12 4-pole connector (only DC mod.)
Dielectric strength	500 Vac, 1 min between electronics and housing
Insulating resistance	>20 MΩ, 500 Vdc between electronics and housing
Electrical protection	class 2 (mod. S300...2/5)
Mechanical protection	IP67 (IEC/EN60529)/cable gland EN50262
Ambient light rejection	according to EN 60947-5-2
Vibrations	0,5 mm amplitude, 10 ... 55 Hz frequency, for every axis (EN60068-2-6)
Shock resistance	11 ms (30 G) 6 shock for every axis (EN60068-2-27)
Housing material	PBT 30% glass fiber-reinforced
Lens material	frontal window and lens in PC
Operating temperature	-40 ... 55 °C
Storage temperature	-40 ... 70 °C
Weight	140 g (mod. S300...2/5), 150 g (mod. S300...1)

DIMENSIONS

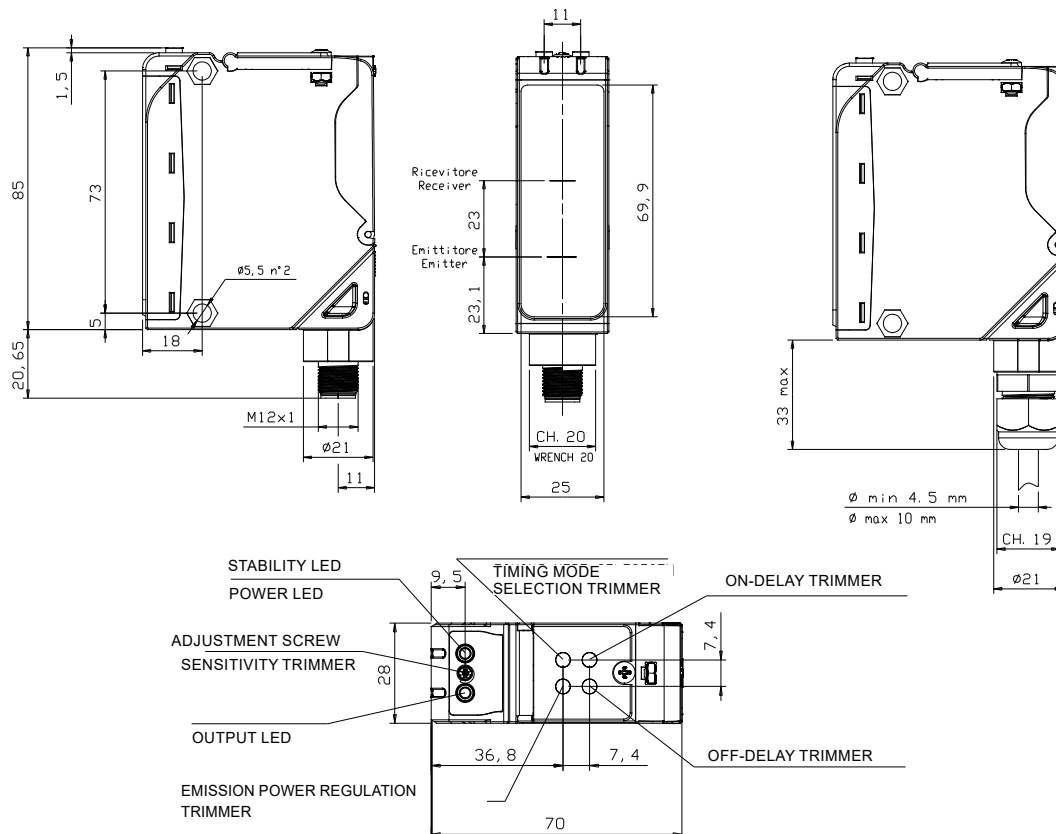

INDICATORS AND SETTINGS

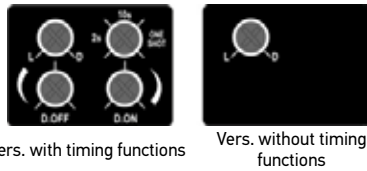
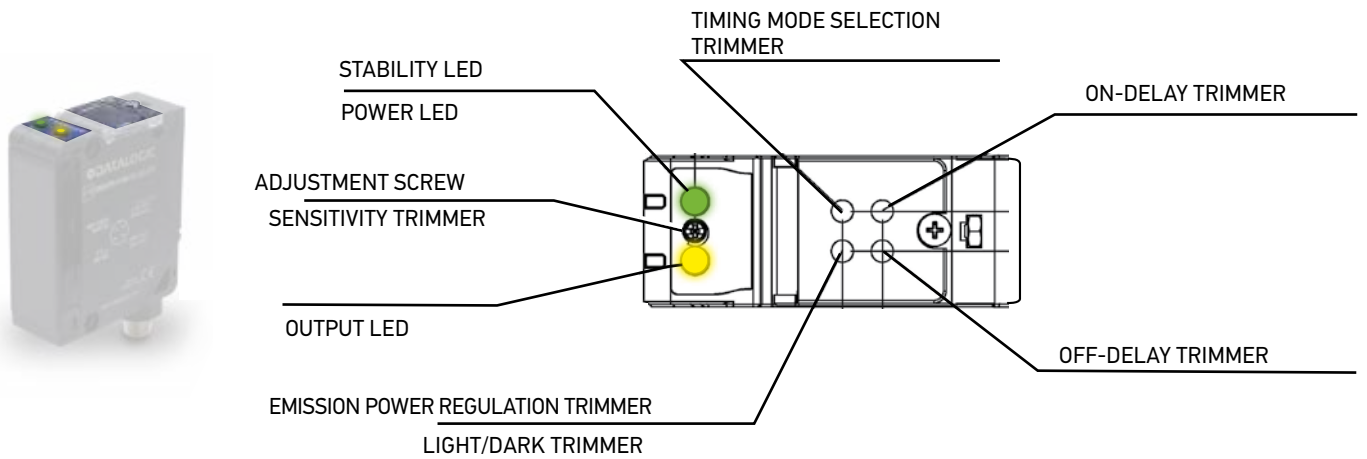

CONNECTIONS

TERMINAL BLOCK

VAC/VDC MODELS

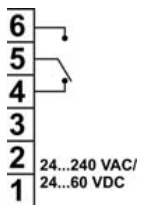

VDC MODELS

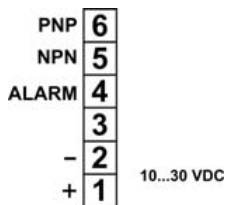

M12 CONNECTOR (only DC models)

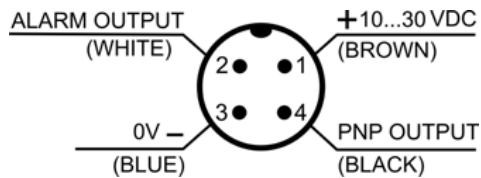

Through beam emitter

TERMINAL BLOCK

AC MODELS

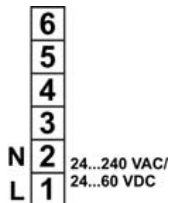

DC MODELS

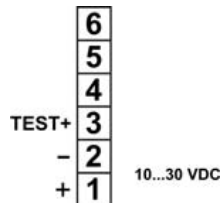

M12 CONNECTOR (only DC models)

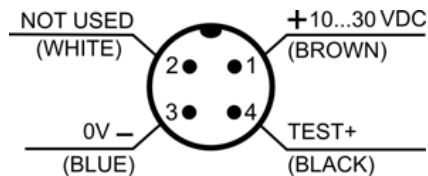

DETECTION DIAGRAMS

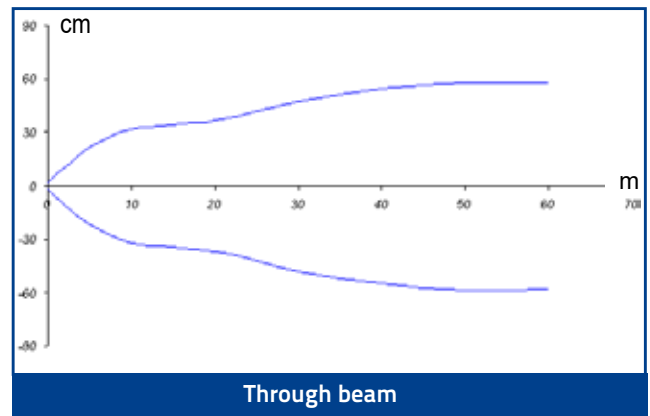
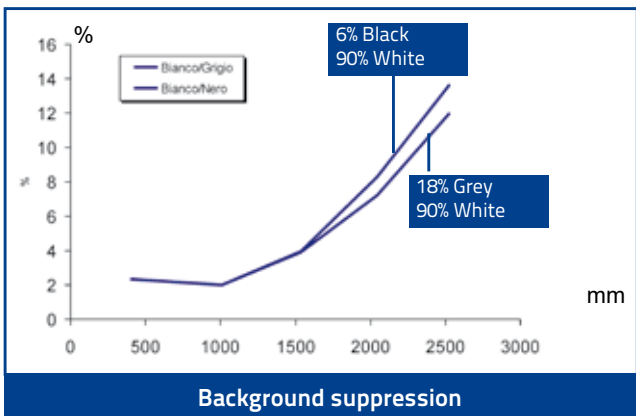
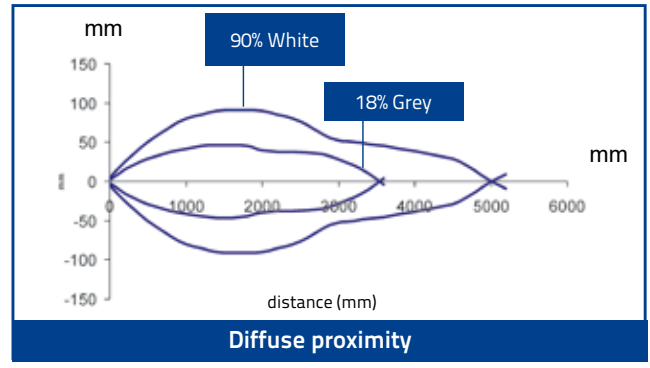
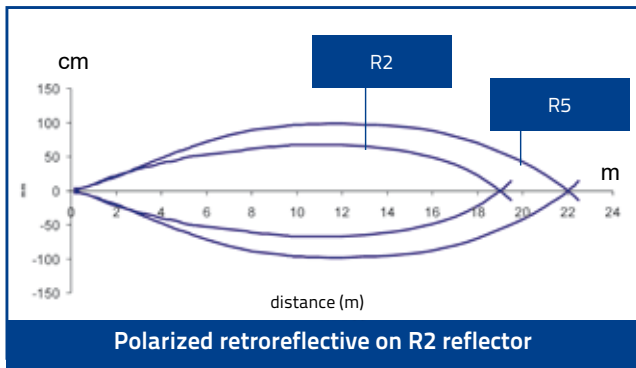

MODEL SELECTION AND ORDER INFORMATION

OPTIC FUNCTION	OUTPUT	CONNECTION	SETTING	MODEL	ORDER NO.	
Polarized retroreflective	NPN/PNP	Vdc - Terminal block	Sensitivity and D/L trimmers	S300-PR-2-B01-OC	951451000	
			Timing, sensitivity and D/L trimmers	S300-PR-2-B06-OC	951451010	
		Vdc - M12 Connector	Sensitivity and D/L trimmers	S300-PR-5-B01-OC	951451020	
			Timing, sensitivity and D/L trimmers	S300-PR-5-B06-OC	951451030	
	Relay	Vac - Terminal block	Sensitivity and D/L trimmers	S300-PR-1-B01-RX	951451040	
			Timing, sensitivity and D/L trimmers	S300-PR-1-B06-RX	951451050	
Diffused proximity	NPN/PNP	Vdc - Terminal block	Sensitivity and D/L trimmers	S300-PR-2-C01-OC	951451070	
			Timing, sensitivity and D/L trimmers	S300-PR-2-C06-OC	951451080	
		Vdc - M12 Connector	Sensitivity and D/L trimmers	S300-PR-5-C01-OC	951451090	
			Timing, sensitivity and D/L trimmers	S300-PR-5-C06-OC	951451100	
		Relay	Vac - Terminal block	Sensitivity and D/L trimmers	S300-PR-1-C01-RX	951451110
				Timing, sensitivity and D/L trimmers	S300-PR-1-C06-RX	951451120
	Through beam receiver	NPN/PNP	Vdc - Terminal block	Sensitivity and D/L trimmers	S300-PR-2-F01-OC	951451210
				Timing, sensitivity and D/L trimmers	S300-PR-2-F06-OC	951451220
			Vdc - M12 Connector	Sensitivity and D/L trimmers	S300-PR-5-F01-OC	951451230
				Timing, sensitivity and D/L trimmers	S300-PR-5-F06-OC	951451240
Through beam emitter	-	Vdc - Terminal block	Emission power regulation trimmer	Sensitivity and D/L trimmers	S300-PR-1-F01-RX	951451250
				Timing, sensitivity and D/L trimmers	S300-PR-1-F06-RX	951451260
		Vdc - M12 Connector	Timing, sensitivity and D/L trimmers; defogging function	S300-PR-1-F06-RX-M	951451270	
				S300-PR-2-G00-EX	951451280	
		Vac - Terminal block	Defogging function	S300-PR-5-G00-EX	951451290	
				S300-PR-1-G00-EX	951451300	
Background suppression	NPN/PNP	Vdc - Terminal block	Sensitivity and D/L trimmers	S300-PR-2-M01-OC	951451140	
			Timing, sensitivity and D/L trimmers	S300-PR-2-M06-OC	951451150	
		Vdc - M12 Connector	Sensitivity and D/L trimmers	S300-PR-5-M01-OC	951451160	
			Timing, sensitivity and D/L trimmers	S300-PR-5-M06-OC	951451170	
	Relay	Vac - Terminal block	Sensitivity and D/L trimmers	S300-PR-1-M01-RX	951451180	
			Timing, sensitivity and D/L trimmers	S300-PR-1-M06-RX	951451190	
			Timing, sensitivity and D/L trimmers; defogging function	S300-PR-1-M06-RX-M	951451200	

ACCESSORIES

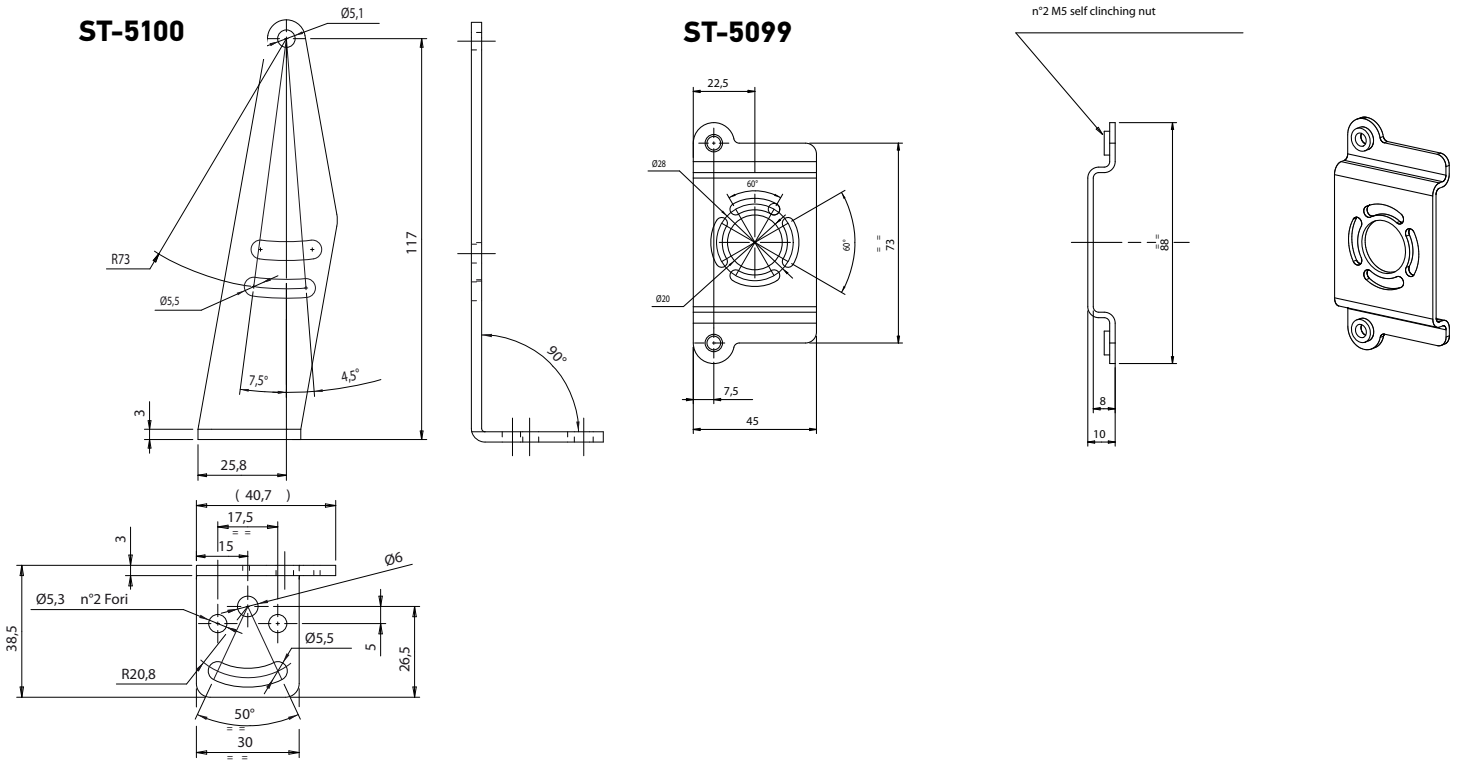

MODEL	DESCRIPTION	ORDER No.
ST-5099	mounting BRACKET	95ACC2830
ST-5100	mounting BRACKET	95ACC2840

CABLES

TYPE	DESCRIPTION	LENGTH	MODEL	ORDER No.
Axial M12 Connector	4-pole, grey, P.V.C.	3 m	CS-A1-02-G-03	95A251380
		5 m	CS-A1-02-G-05	95A251270
		7 m	CS-A1-02-G-07	95A251280
		10 m	CS-A1-02-G-10	95A251390
	4-pole, P.U.R.	2 m	CS-A1-02-R-02	95A251540
		5 m	CS-A1-02-R-05	95A251560
Radial M12 Connector	4-pole, grey, P.V.C.	3 m	CS-A2-02-G-03	95A251360
		5 m	CS-A2-02-G-05	95A251240
		7 m	CS-A2-02-G-07	95A251245
		10 m	CS-A2-02-G-10	95A251260
	4-pole, P.U.R.	2 m	CS-A2-02-R-02	95A251550
		5 m	CS-A2-02-R-05	95A251570
Axial M12 Connector	4-pole, shielded, black, P.V.C.	3 m	CV-A1-22-B-03	95ACC1480
		5 m	CV-A1-22-B-05	95ACC1490
		10 m	CV-A1-22-B-10	95ACC1500
		15 m	CV-A1-22-B-15	95ACC2070
		25 m	CV-A1-22-B-25	95ACC2090
Radial M12 Connector	4-pole, shielded, black, P.V.C.	3 m	CV-A2-22-B-03	95ACC1540
		5 m	CV-A2-22-B-05	95ACC1550
		10 m	CV-A2-22-B-10	95ACC1560
Axial M12 Connector	4-pole, U.L., black, P.V.C.	3 m	CS-A1-02-U-03	95ASE1120
		5 m	CS-A1-02-U-05	95ASE1130
		10 m	CS-A1-02-U-10	95ASE1140
		15 m	CS-A1-02-U-15	95ASE1150
		25 m	CS-A1-02-U-25	95ASE1160
Radial M12 Connector	4-pole, black	Connector- not cabled	CS-A1-02-B-NC	G5085002
Radial M12 Connector	4-pole, black	Connector- not cabled	CS-A2-02-B-NC	G5085003